



BB Axial piston pumps
MB Axial piston motors



BB AXIAL PISTON PUMPS MB AXIAL PISTON MOTORS

BB AXIAL PISTON PUMPS and MB AXIAL PISTON MOTORS

BB/MB series are a further development of our well known pumps and motors for truck applications. FHER piston pumps have been in production for more than 50 years and have distinguished themselves by their outstanding reliability and high output in hundreds of applications.

The BB offer additional advantages compared with our classical BA or BHE piston pumps that have been operating during decades.

Series BB "bent-axis" axial piston pumps and motors are designed to meet all operational requirements such as high rate of flow, high pressure, low weight, compactness, direct connection to truck power take-off's and easy and inexpensive mounting installation.

Operators of cranes, dumpers, hook loaders, forest cranes or similar truck applications will find a very efficient pump.

Main BB and MB advantages:

- High Speeds
- Low noise level
- Operating pressure to 350 bar
- Small installation dimensions
- Low weight
- High volumetric and mechanical efficiencies
- Wide range of flows, (from 20c.c./rev. to 110 c.c./rev.)

Main BB and MB technical achievements:

- Spherical pistons allowing high speeds
- 40°, (20° in BB20 and BB30) bent-axis angle
- Optimal inlet port geometry
- Laminated piston rings allowing low leakage
- Tolerates low and high temperature changes
- Possibility of installation above the oil tank level
- Mounting flange and shaft meet the ISO standard
- MB axial piston motor allows high torque and acceleration

INSTALLATION AND TECHNICAL DATA

INSTALLATION AND START UP

All pumps have shaft end and 4-hole mounting flange according ISO 7653 for direct mounting to the PTO. BB pumps can be driven by the PTO of the truck, an electric motor, diesel engine (with an elastic coupling) or cardan shaft. If a V-Belt is to be used, please consult us.

Mounting position: the drive shaft should be horizontal.

If pump is mounted above the tank level, special measures should be taken to assure that the pump will be full of oil under all circumstances.

Initial start up:

Clean all the hydraulic system before filling with oil. Fill the pump with oil thru the suction and pressure orifices.

If the pump is mounted above the tank, fill also thru the screw plug in the housing. BB pumps are self bleeding and self priming. Start without pressure at a moderate speed (500 r.p.m.). If no oil flow is detected after 15 seconds, stop and check that the suction line is open and the direction of rotation is correct.

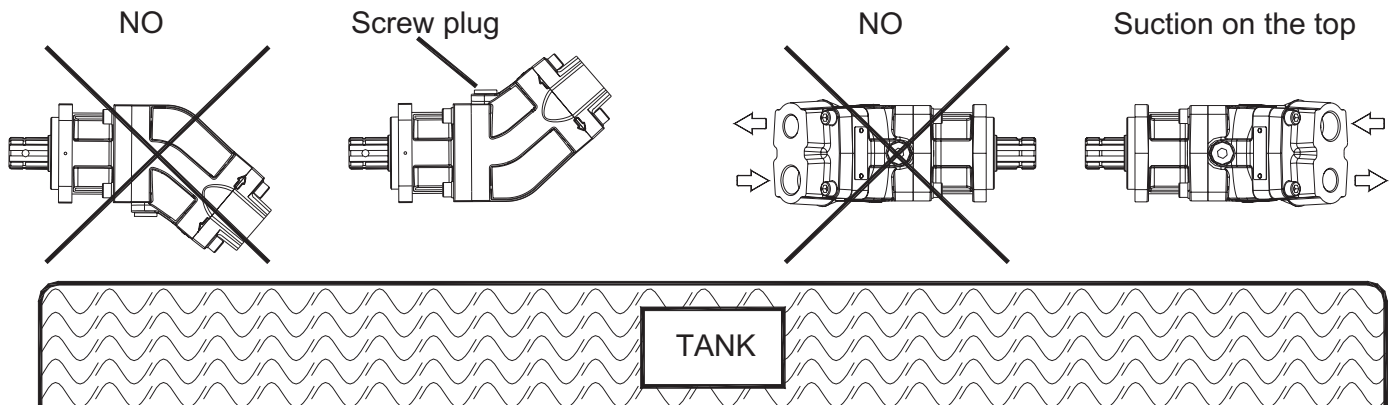

HYDRAULIC FLUID

Use mineral based oils for hydraulic systems.

To select the correct viscosity, the operating temperature of the oil, measured in the tank should be considered.

At operating temperature, the viscosity of the oil should be within the range of 20-35 cSt.

The oil in the housing of the pump (leakage oil) is typically at a higher temperature than the tank temperature. Maximum temperature at any point in the system must be less than 90°C.

If this temperature is exceeded in the housing of the pump, special shaft seals should be used. (Add option «F» to the ordering code).

Please, use the following guidelines to choose the correct oil grade:

20-40 ° C : VG 22 - VG 32.

40-60 ° C : VG 32 - VG 46.

60-90 ° C : VG 68 - VG 100.

FILTRATION

The finer the filtration, the better the achieved purity grade of the fluid, and the longer the life of the pump. Purity grades of 18/13 (ISO 4406) or 9 (NAS 1638) should be guaranteed by the filtration system.

We suggest a return filter, (avoid a filter in the suction line) with a mesh from 10 µm (high pressure and/or contaminated environment) to 25 µm (low pressure and clean environment).

The flow capacity of the filter should be at least twice the pump flow under the operating conditions.



BB AXIAL PISTON PUMPS MB AXIAL PISTON MOTORS

ROTATION

Direction of rotation of the pump can be changed removing the four screws of the iron cover, to rotate it 180°. An arrow is drawn up in both housing and cover indicating the direction of rotation.

With no other indication of the customer, all the pumps are supplied with clockwise rotation.

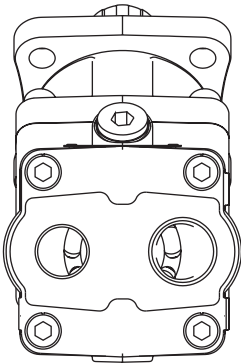
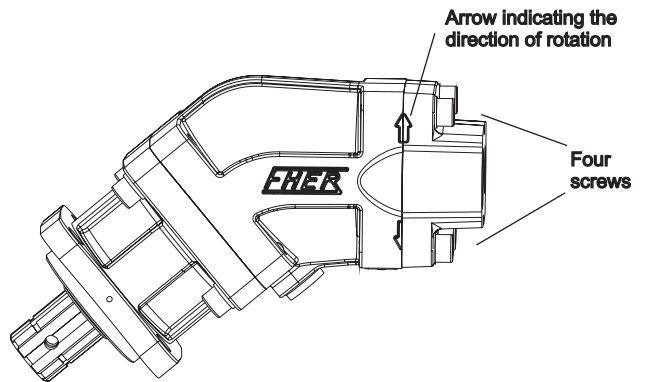

Counterclockwise rotation

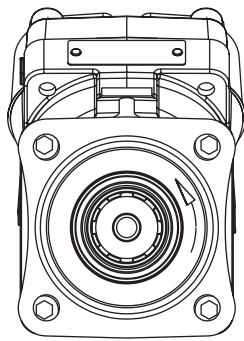

Clockwise rotation

DRAIN LINE

BB pumps are internally drained. A drain line is therefore not necessary.
MB bidirectional motors need a direct to tank drain line.

WORKING PRESSURE

Inlet side: Min. 0,8 Bar (absolute). Max. 2 Bar (absolute).
Outlet side: Constant pressure 300 Bar, intermittent pressure 350 Bar.

Ordering code

***B / 60 / F / 2 / S / R**

- Rotation: R= Right hand (clockwise), L=Left (counterclockwise).
- S: Special mounting flange. Not used with standard flange ISO 7653.
- 2: Special shaft number. Not used with standard splined shaft 8x32x36 DIN 5462.
- F: FPM seals. For housing temperatures higher than 90°C, or non mineral fluids. Not used with standard NBR seals.
- Size, (C.C. /Rev.): 20, 30, 40, 60, 78 (Intermittent pressure 300 Bar.), 80 and 110.
- BB: Fixed displacement axial piston pump, bent axis design. Intermittent pressure 350 Bar.
- MB: Fixed displacement axial piston motor, bent axis design. Intermittent pressure 300 Bar.



Axial piston pump BB20 - BB30
Axial piston motor MB20 - MB30

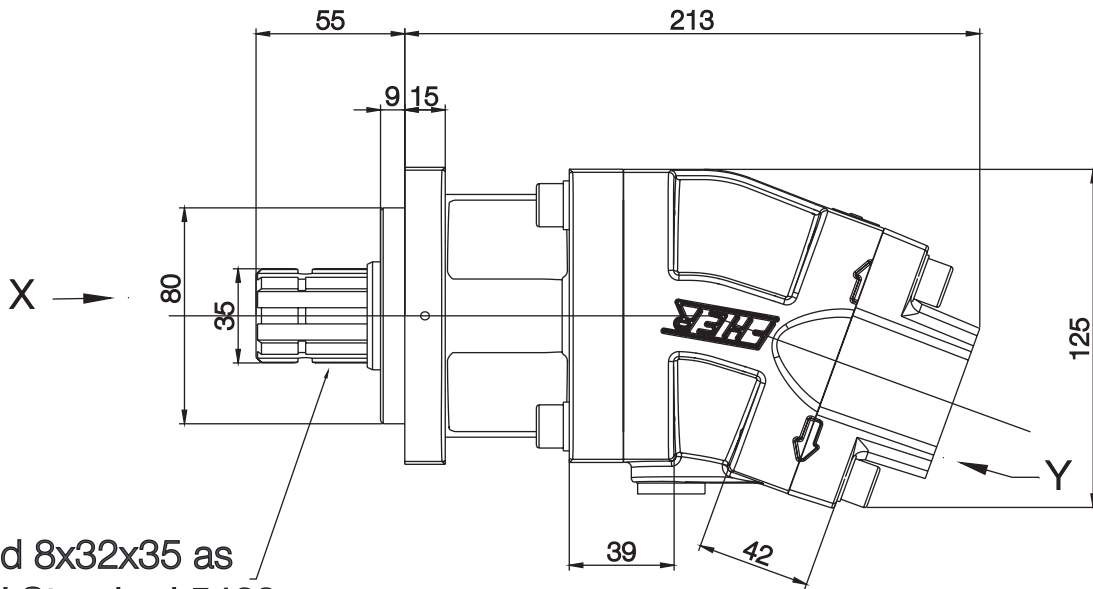

Splined 8x32x35 as per DIN Standard 5462

View per X

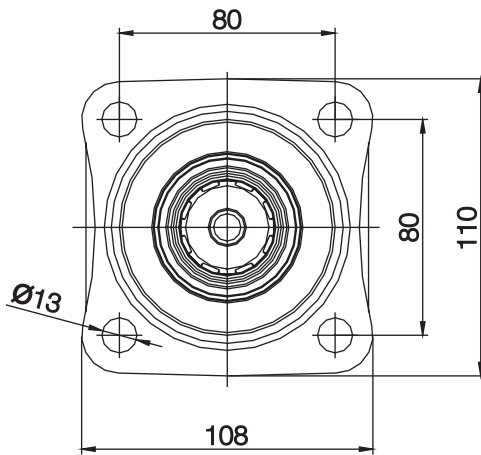

View per Y

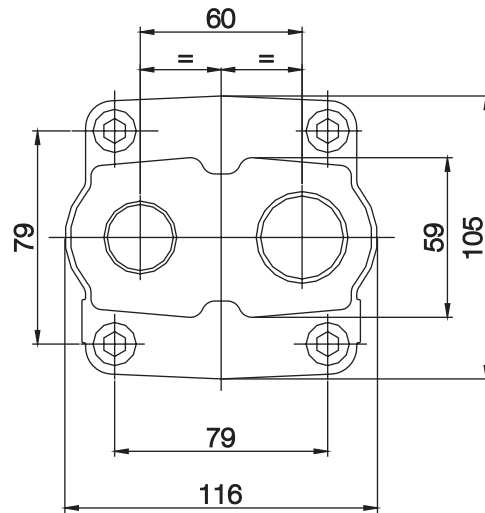

SPECIFICATIONS

Model	Flow at 1.000 rpm	Continuous pressure	Intermittent pressure	Continuous speed	Intermittent speed	Inlet E	Outlet S	Weight
BB20	21 ltrs./min	300 Bar	350 Bar	2.300 rpm	3.000 rpm	1 BSP	3/4 BSP	8,1 Kgs.
BB30	30 ltrs./min	300 Bar	350 Bar	2.000 rpm	2.700 rpm	1 BSP	3/4 BSP	8,1 Kgs.
MB20	21 ltrs./min	250 Bar	300 Bar	2.300 rpm	3.000 rpm	3/4 BSP	3/4 BSP	8,1 Kgs.
MB30	30 ltrs./min	250 Bar	300 Bar	2.000 rpm	2.700 rpm	3/4 BSP	3/4 BSP	8,1 Kgs.

1.02.01



Axial piston pump BB20 - BB30 Axial piston motor MB20 - MB30

FLOW
(lts./min)

BB20

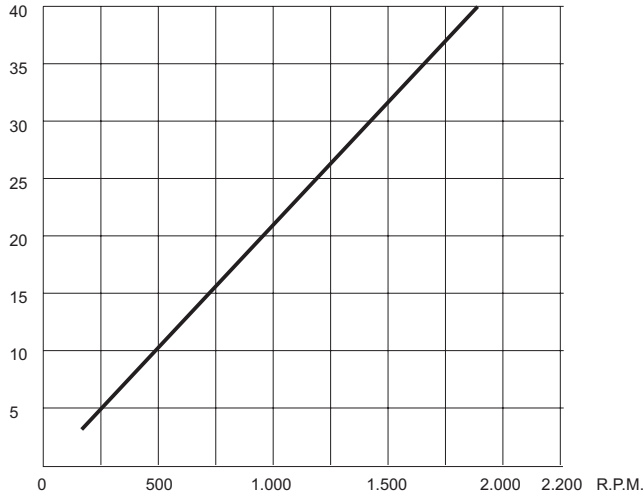

TORQUE
(Nw.m)

BB20

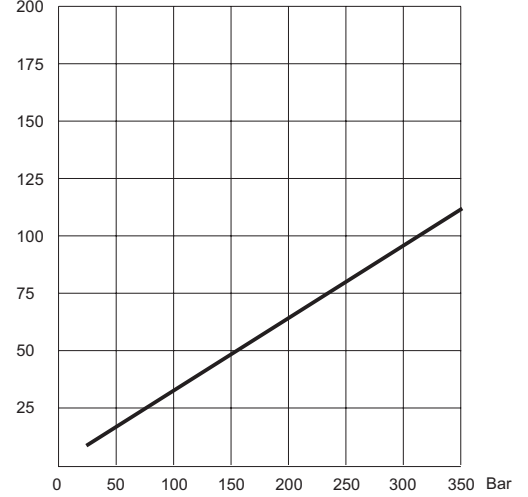

FLOW
(lts./min)

BB30

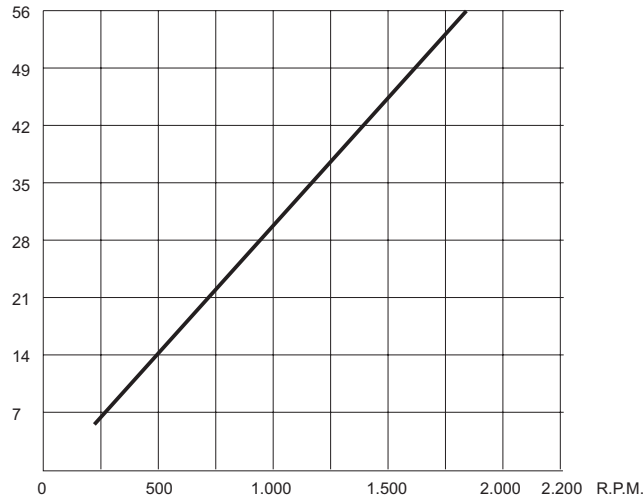

TORQUE
(Nw.m)

BB30

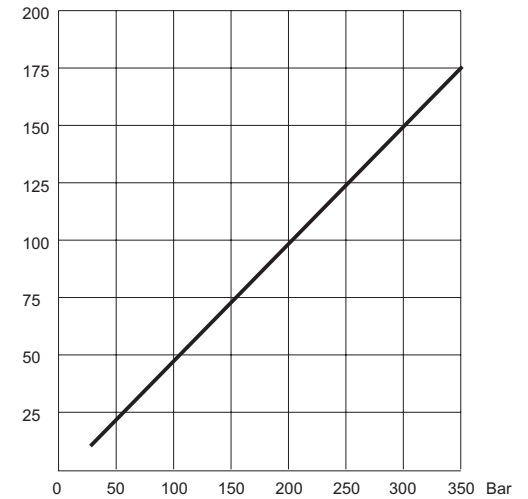

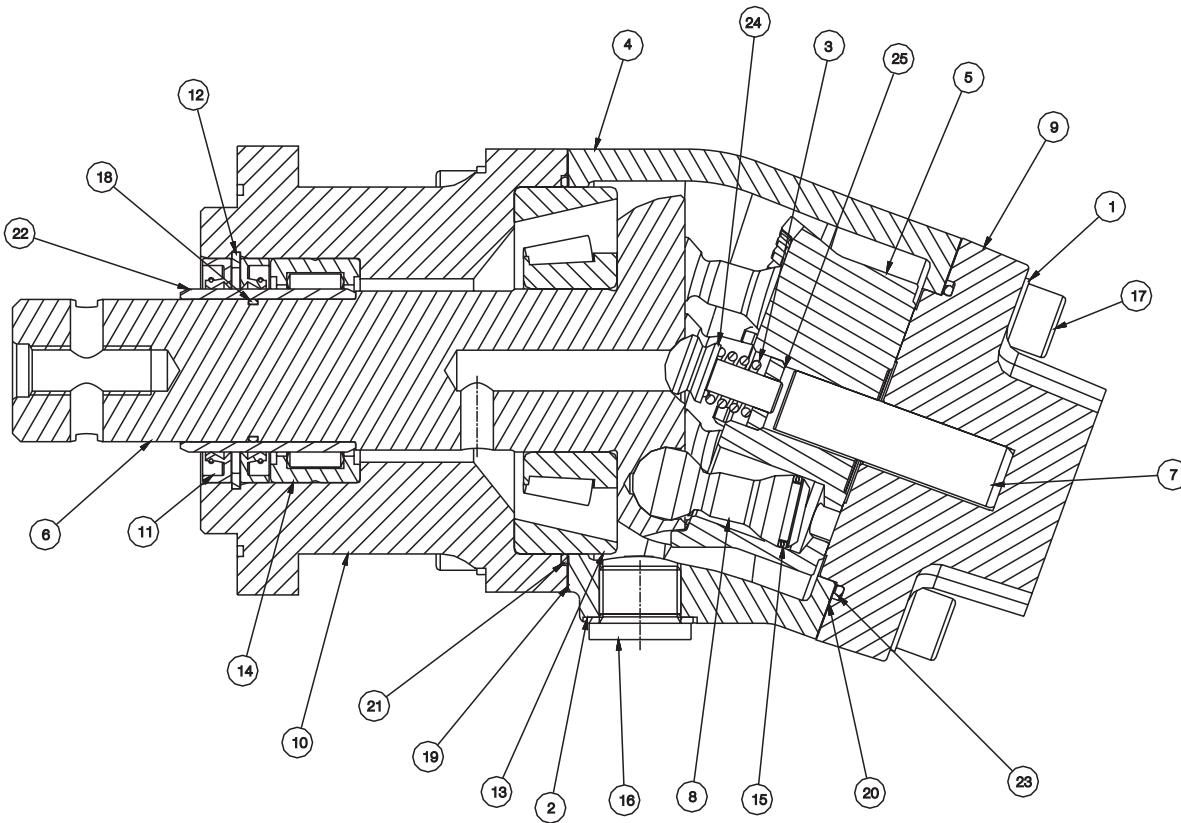

ELE	DESCRIPCIÓN	DESCRIPTION
1	Arandela Grower	Grower washer
2	Junta USIT	USIT seal
3	Muelle	Spring
4	Cuerpo acodado Aluminio	Body
5	Tambor	Barrel
6	Eje bomba	Pump shaft
7	Eje tambor	Barrel shaft
8	Piston	Piston
9	Tapa bomba	Pump cover
10	Cuerpo de rodamientos	Bearings's body
11	Reten	Shaft seal
12	Grupilla	Retaining ring
13	Rodamiento de rodillos conicos	Roller bearing
14	Rodamiento de agujas	Needle rollerbearing
15	Segmento	Piston ring
16	Tapon roscado	Screw plug
17	Tomillo de cabeza cilíndrica	Cylindrical-head screw
18	Junta Torica del eje	Shaft O-ring seal
19	Junta cuerpo-cuerpo	Body-body seal
20	Junta tapa-cuerpo	Cover-body seal
21	Junta torica cuerpo de rodamientos	Bearings's body O-ring seal
22	Casquillo para retenes y rodamiento	Bushing for oil seal and bearing
23	Junta torica tapa	Cover O-ring seal
24	Rotula apoyo muelle	Thrust ball
25	Tope muelle	Spring top



Axial piston pump BB40 - BB60 - BB78
Axial piston motor MB40 - MB60 - MB78

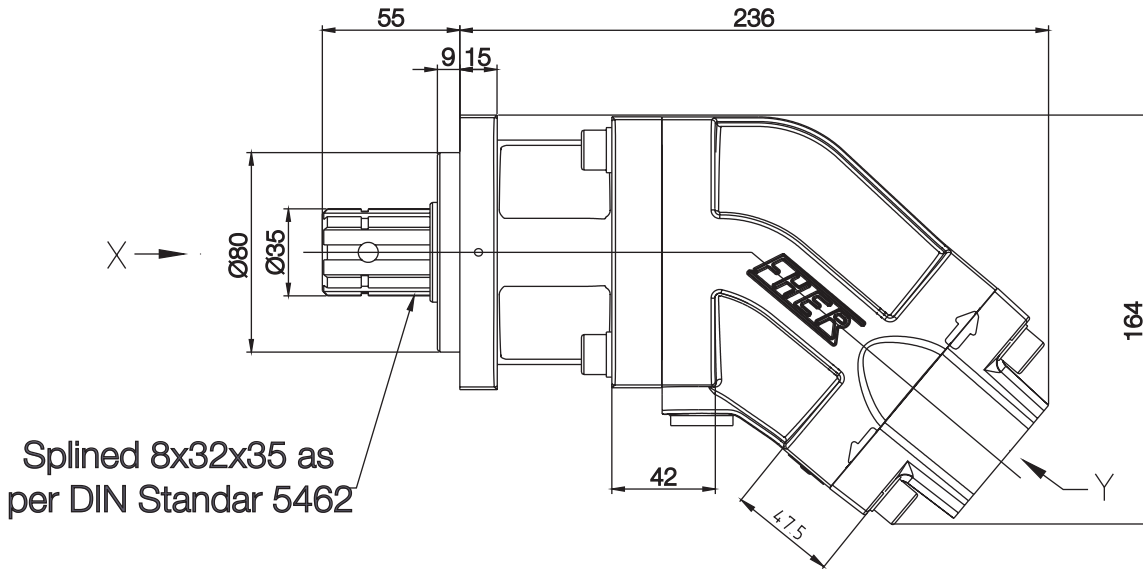

View per X

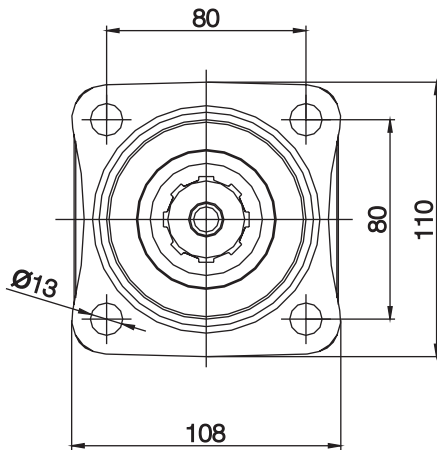

View per Y

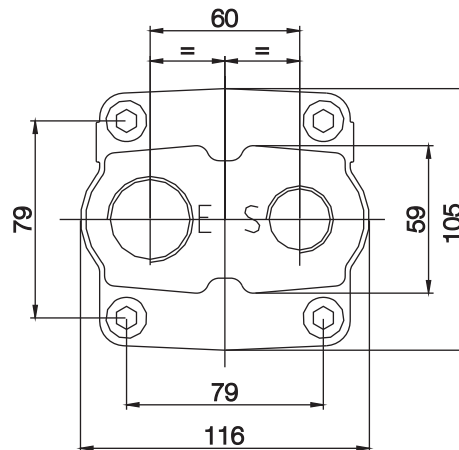

SPECIFICATIONS

Model	Flow at 1.000 rpm	Continuous pressure	Intermittent pressure	Continuous speed	Intermittent speed	Inlet E	Outlet S	Weight
BB40	45 ltrs./min.	300 Bar	350 Bar	1.500 rpm	2.200 rpm	1 BSP	3/4 BSP	9,8 Kgs.
BB60	63 ltrs./min.	300 Bar	350 Bar	1.500 rpm	2.200 rpm	1 BSP	3/4 BSP	9,8 Kgs.
BB78	78 ltrs./min.	225 Bar	300 Bar	1.500 rpm	2.000 rpm	1 1/4 BSP	1 BSP	9,8 Kgs.
MB40	45 ltrs./min.	300 Bar	300 Bar	1.500 rpm	2.200 rpm	3/4 BSP	3/4 BSP	9,8 Kgs.
MB60	63 ltrs./min.	300 Bar	300 Bar	1.500 rpm	2.200 rpm	3/4 BSP	3/4 BSP	9,8 Kgs.
MB78	78 ltrs./min.	225 Bar	300 Bar	1.500 rpm	2.000 rpm	3/4 BSP	1 BSP	9,8 Kgs.

1.02.04



Axial piston pump BB40 - BB60 - BB78 Axial piston motor MB40 - MB60 - MB78

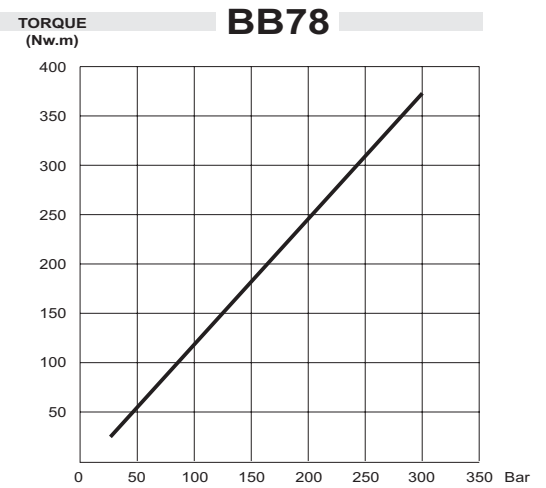
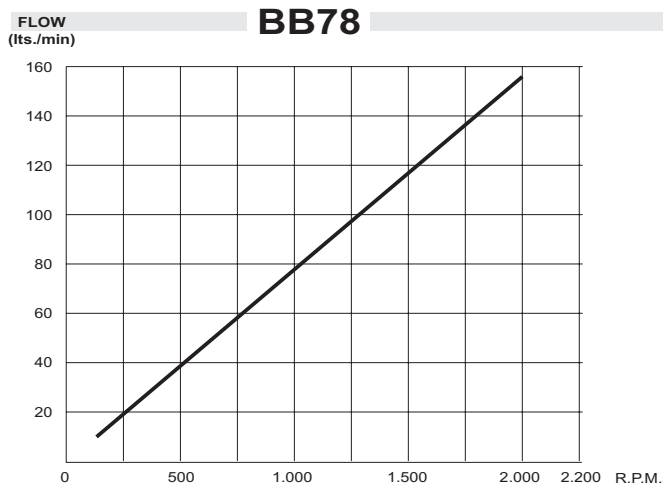
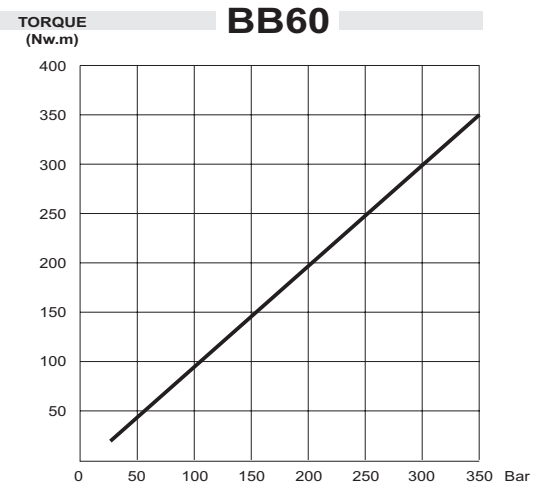
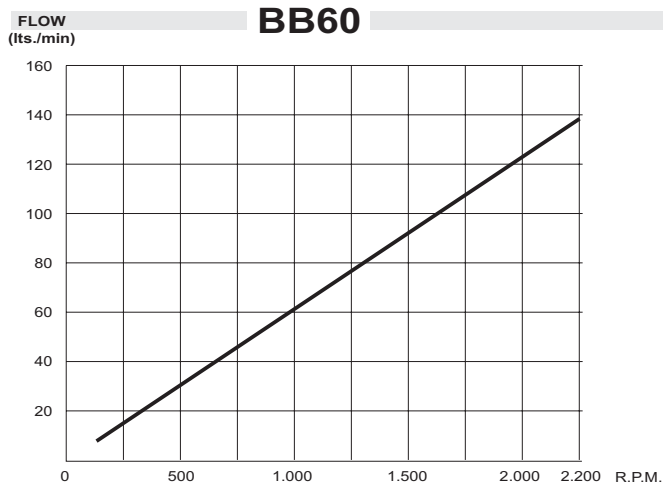
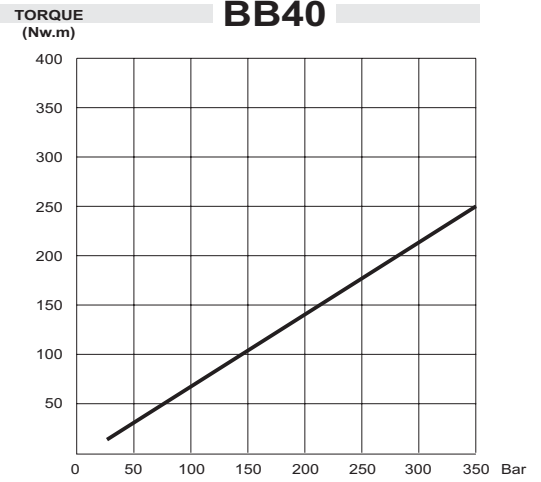
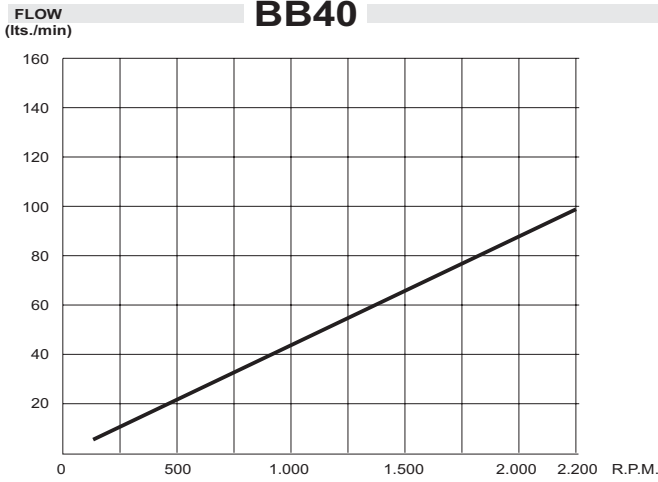

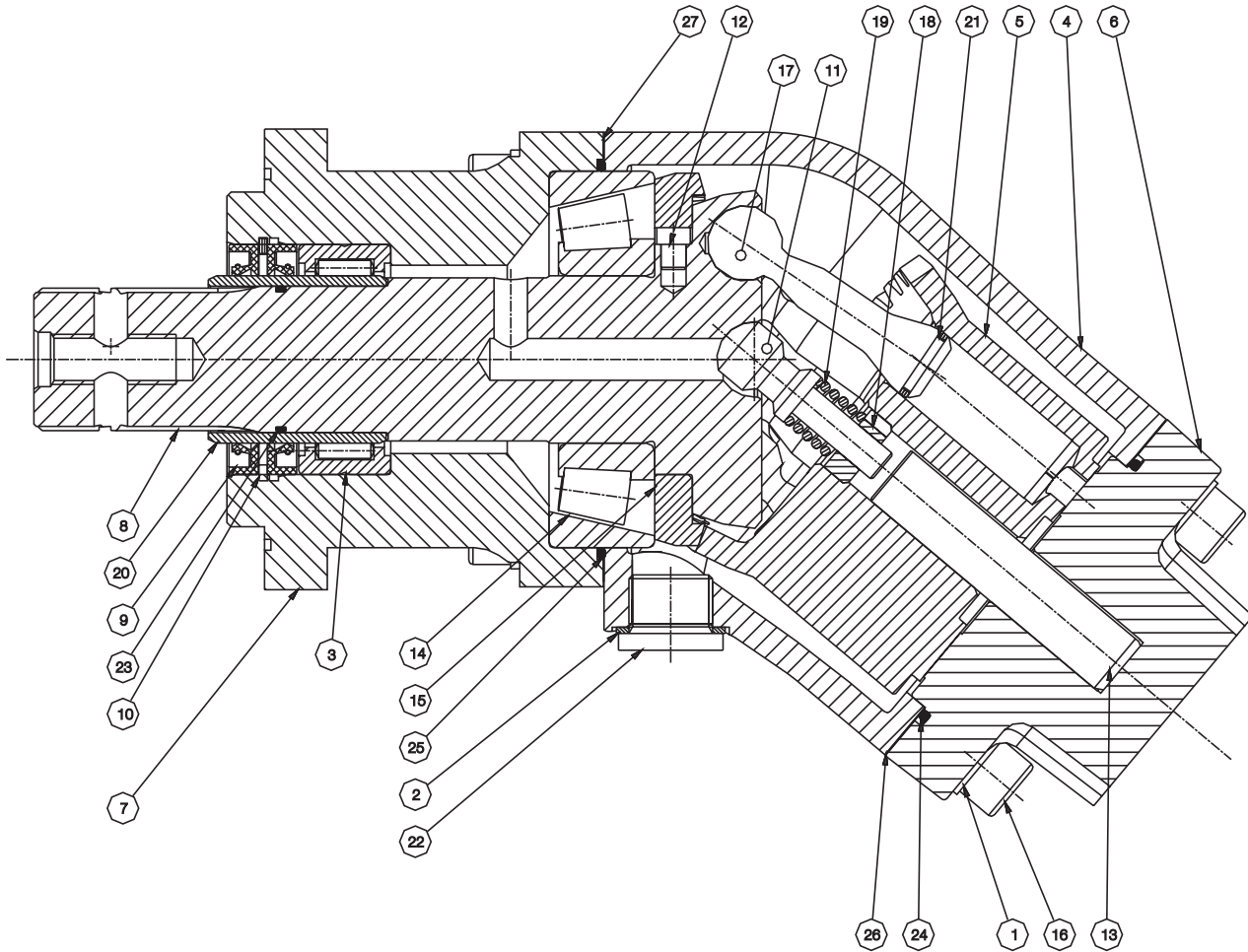

ELE	DESCRIPCIÓN	DESCRIPTION
1	Arandela Grower	Grower washer
2	Junta USIT	USIT seal
3	Rodamiento de agujas	Needle rollerbearing
4	Cuerpo acodado Aluminio	Body
5	Tambor	Barrel
6	Tapa bomba	Pump cover
7	Cuerpo de rodamientos	Bearings's body
8	Eje bomba	Pump shaft
9	Reten	Shaft seal
10	Grupilla	Retaining ring
11	Rotula apoyo muelle	Thrust ball
12	Chaveta	Key
13	Eje tambor	Barrel shaft
14	Rodamiento de rodillos conicos	Roller bearing
15	Corona	Timing gear
16	Tornillo de cabeza cilíndrica	Cylindrical-head screw
17	Piston	Piston
18	Muelle	Spring
19	Tope muelle	Spring top
20	Casquillo para retenes y rodamiento	Bushing for oil seal and bearing
21	Segmento	Piston ring
22	Tapon roscado	Screw plug
23	Junta Torica del eje	Shaft O-ring seal
24	Junta torica tapa	Cover O-ring seal
25	Junta torica cuerpo de rodamientos	Bearings's body O-ring seal
26	Junta tapa-cuerpo	Cover-body seal
27	Junta cuerpo-cuerpo	Body-body seal



Axial piston pump BB80 - BB110
Axial piston motor MB80 - MB110

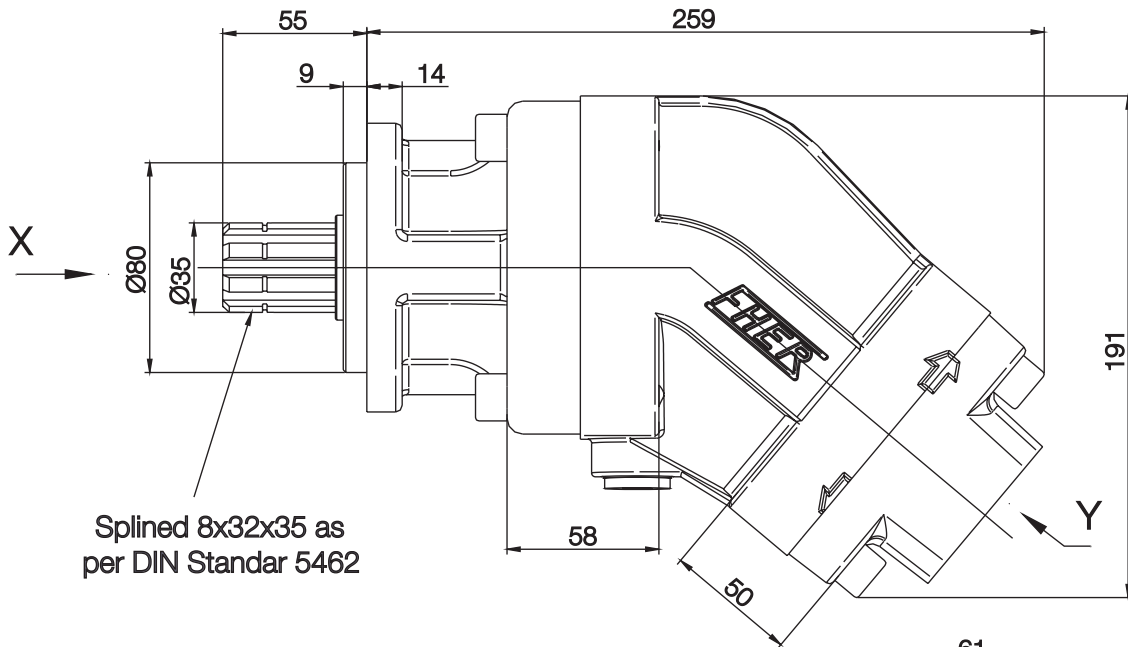

Splined 8x32x35 as per DIN Standar 5462

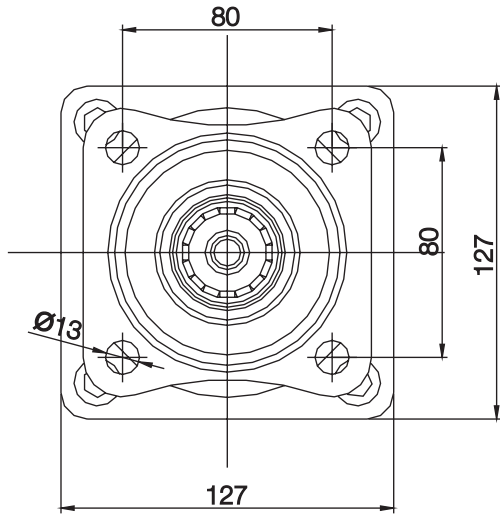

View per X

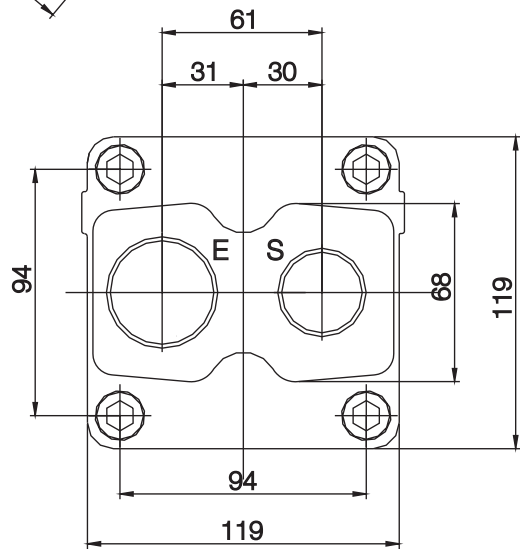

View per Y

SPECIFICATIONS

Model	Flow at 1.000 rpm	Continuous pressure	Peak pressure	Continuous speed	Peak speed	Inlet E	Outlet S	Weight
BB80	80 ltrs./min.	300 Bar	350 Bar	1.500 rpm	2.000 rpm	1 1/4 BSP	1 BSP	14,2 Kgs.
BB110	112 ltrs./min	300 Bar	350 Bar	1.500 rpm	1.800 rpm	1 1/4 BSP	1 BSP	14,2 Kgs.
MB80	80 ltrs./min.	300 Bar	300 Bar	1.500 rpm	2.000 rpm	1 BSP	1 BSP	14,2 Kgs.
MB110	112 ltrs./min	300 Bar	300 Bar	1.500 rpm	1.800 rpm	1 BSP	1 BSP	14,2 Kgs.

1.02.07



Axial piston pump BB80 - BB110 Axial piston motor MB80 - MB110

FLOW
(lts./min)

BB80

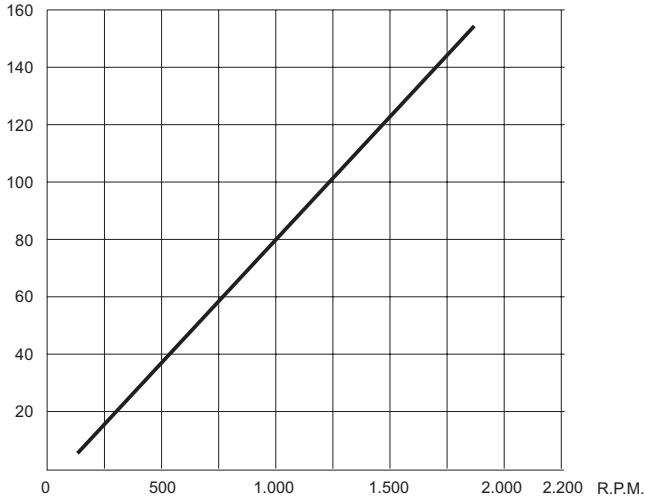

TORQUE
(Nw.m)

BB80

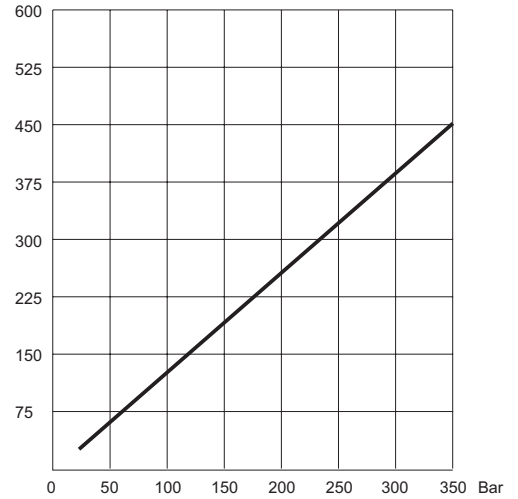

FLOW
(lts./min)

BB110

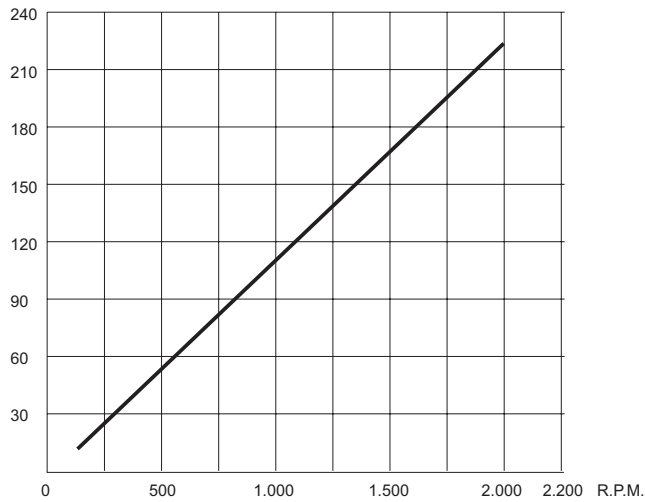

TORQUE
(Nw.m)

BB110

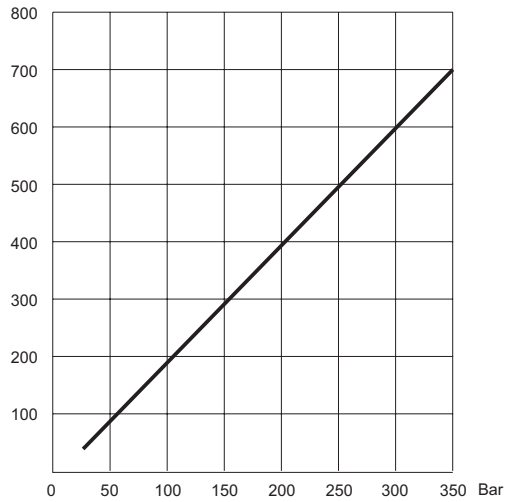

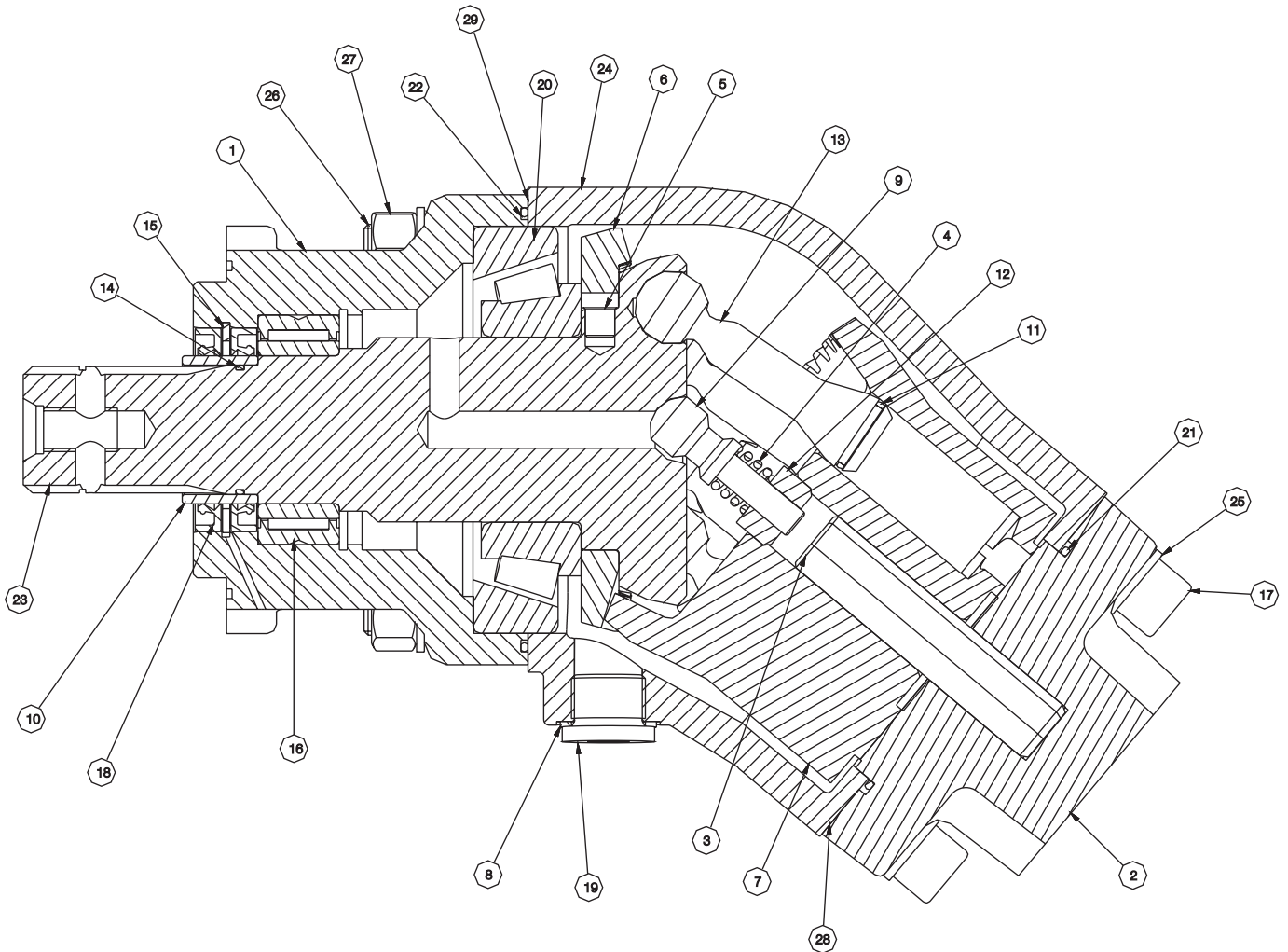

ELE	DESCRIPCIÓN	DESCRIPTION
1	Cuerpo de rodamientos	Bearings's body
2	Tapa bomba	Pump cover
3	Eje tambor	Barrel shaft
4	Muelle	Spring
5	Chaveta	Key
6	Corona	Timing gear
7	Tambor	Barrel
8	Junta USIT	USIT seal
9	Rotula apoyo muelle	Thrust ball
10	Casquillo para retenes y rodamiento	Bushing for oil seal and bearing
11	Segmento	Piston ring
12	Tope muelle	Spring top
13	Piston	Piston
14	Junta Torica del eje	Shaft O-ring seal
15	Grupilla	Retaining ring
16	Rodamiento de agujas	Needle rollerbearing
17	Tomillo de cabeza cilíndrica	Cylindrical-head screw
18	Reten	Shaft seal
19	Tapon roscado	Screw plug
20	Rodamiento de rodillos conicos	Roller bearing
21	Junta torica tapa	Cover O-ring seal
22	Junta torica cuerpo de rodamientos	Bearings's body O-ring seal
23	Eje bomba	Pump shaft
24	Cuerpo acodado Aluminio	Body
25	Arandela Grower	Grower washer
26	Varilla roscada M12	Stud
27	Tuerca M12	Nut
28	Junta tapa-cuerpo	Cover-body seal
29	Junta cuerpo-cuerpo	Body-body seal