

# **HYDRAULIC VANE PUMPS**

Versión Corel 1.0: 01-06-06

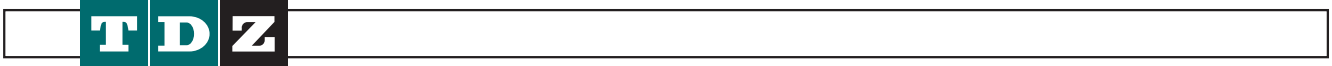

hydraulics

**BH\*, V\* & DT6 HYDRAULIC VANE PUMPS**

## INTRODUCTION

**TDZ** vane pumps are manufactured in a wide range of displacements, from 2 cc/r to 269 cc/rev. for single pumps, 460 cc/rev. for double pumps and 560 cc/rev. for triple pumps.

All **TDZ** pumps have a low power to weight ratio, high efficiency, low noise levels, optional inlet and outlet port positions and ease of maintenance.

Ease of maintenance is achieved by the pump design, where the working components are contained within a cartridge which can quickly and easily be replaced without disconnecting the pump from the prime mover or moving it away from the pipe work. **TDZ** vane pumps are hydraulically balanced, reducing wear and eliminating bearing loads from within the pump.

The option to rotate the outlet port 90 degrees in relation to the inlet port provides flexibility and easy installation.

Depending on the application, there are three versions of the larger single, double and triple vane pumps: low noise industrial models VS and BHS, mobile models VQ and BHQ and multi-purpose models DT6 (275 bar).

Models VS, VQ and DT6 have UNC threads for the port flanges whilst models BHS, BHQ have metric threads. On single pumps the outlet port is at the shaft end for models VS, VQ, DT6 on models BHS and BHQ the outlet port is at the cover end.

**V\* & BH\* HYDRAULIC VANE PUMPS**

## INTRODUCTION

**PUMP DRIVE**

Direct coaxial drive is recommended via flexible coupling. For indirect drives imposing a radial load on the shaft, consult **TDZ HYDRAULICS S.A.** or your nearest distributor for advice.

**ROTATION**

The direction of rotation can be reversed by turning the ring, rotor and vanes through 180 degrees. Direction of rotation is viewed from the shaft end.

**STARTING**

**TDZ** vane pumps are self priming, however, if possible, fill the pump with oil before starting or bleed the outlet port while the pump is running to remove any trapped air.

**FILTRATION**

For satisfactory service life, full flow filtration to provide fluid cleanliness conforming to ISO code 18/15 or better is recommended.

**HYDRAULIC FLUIDS**

Use antiwear industrial hydraulic oils with a viscosity of 25-49 cST. Automotive crankcase oils SAE10-SAE20 may also be used depending on the operating temperature.

The optimum operating temperature is 50 °C with a maximum of 70 °C. At higher temperatures service life is decreased with degradation of the wearing parts and seals.

For fire resistance fluids, the "F3" version with special seals must be used at reduced pressures and speeds as indicated below.

**MAXIMUM SPEED RANGES**

With antiwear fluids: 1800 to 2500 rpm (depending on model type. See performance chart).

With synthetic fluids, water glycols and water in oil emulsions, the maximum recommended speed is 1200 rpm. A special version of the BHP2 pump is available for speeds up to 5000 rpm

Speeds shown are given as a guide only based on the correct fluid and correct suction characteristics as recommended by our Technical Services department.

Long or restricted suction lines can cause cavitation, therefore the maximum running speed must be reduced. Avoid using 90 degree elbows in suction lines, use swept bends where possible. Too viscous fluids will also cause cavitation.

When using lower displacement pumps within a given pump frame size, speeds slightly higher than those shown in the charts are acceptable.

For antiwear hydraulic fluids and water glycols, the inlet pressure must not exceed 0.2 bar vacuum, for synthetic fluids and water in oil emulsions, the inlet pressure must not exceed 0.1 bar vacuum.

**MINIMUM SPEED:** 600 rpm

This data is for V\*20, V\*25, V\* 35, V\* 45, BH\*4, BH\* 6, BH\*7, double and triple pumps. For other pumps see chart.

The intermittent pressures shown in the table can be maintained for 10% of the time, with a maximum duration of 6 seconds/minute.

**V\* & BH\* HYDRAULIC VANE PUMPS**

INTRODUCTION

**INTRODUCTION**

**MAXIMUM CONSTANT PRESSURE**

Anti-wear Hydraulic Oil: **from 175 to 210 Bar**  
 Synthetic Oil: **from 175 to 210 Bar**  
 Water-Glycol emulsions: **160 Bar**  
 Water-in-oil emulsions: **70 Bar**

**SOUND LEVEL**

Single Pumps:  
 VS25 and BHS4: 62 dB (A)  
 VS35 and BHS6: 65 dB (A)  
 VS45 and BHS7: 71 dB (A)

Double Pumps:  
 VS43: 68 dB (A)  
 VS63: 69 dB (A)  
 VS73: 71 dB (A)  
 VS64: 69 dB (A)  
 VS74: 71 dB (A)  
 VS76: 72 dB (A)

Sound levels measured with hydraulic oil at 140 Bar, 1500 rpm and a vacuum at pump inlet of 0,17 Bar.

**ADMISSIBLE TORQUES FOR THE SHAFTS**

All the shafts available for our single pumps and motors are sufficient for working at the maximum pressure specified for each model.

However, in the case of double pumps and thru drive pumps, if both cartridges/pumps work simultaneously under pressure, the sum of the torques absorbed for each of them may exceed the resistance of the shaft.

In practice, the absorbed torque for each cartridge/pump may be calculated with the formula:

$$T = \frac{P \times V}{59}$$

Where: T = Torque in Nm.  
 P = Working pressure in Bars.  
 V = Cubage in cm<sup>3</sup>/rev. or flow in lts/min at 1,000 R.P.M.

In order to choose the most appropriate type of shaft, calculate said torque sum under the most unfavourable working conditions and compare them with the torque values admitted for each shaft as indicated in table 1.

Analogically, in the thru drive pumps, the absorbed torque for the second pump will be calculated under the most unfavourable conditions, and it must be checked that it does not exceed the torque values admissible as indicated in table 2 for each connection.

**Table 1**

Pump Type	Shaft n°	Max.Torque Nm
V*42	1	313
V*43	11	313
V*4T	86	392
V*63	1	392
V*64	11	568
V*6T	86	588
V*73	1	588
V*74	11	803
V*76	86	803
V*7T		

**Table 2**

Rear Flange (Conection)	Max. Torque Nm
A	130
B	315
C	440 (V*6TC) 700 (V*7TC)

## **DT6 HYDRAULIC VANE PUMPS**

### INTRODUCTION

**DT series vane pumps** are fixed displacement and high efficiency pumps. Designed under SAE J744c 2 bolt standards, (excluding T6EDC triple pumps), the complete range includes single, double and triple units with wide possibilities of flow combinations, porting configurations, possibilities of use of fluids other than petroleum-based oil and a vast number of different shafts.

The **DT series** is a hydraulically-balanced design. Quality and composition of materials have been checked and tested over millions of cycles on our experimental test benches. This fact, together with a rigid bearing and a high resistance to particle contamination thanks to the double lip vane, makes DT series pumps long -life hydraulic units.

Within 3 different cartridge kit sizes, flows available range from 3 to 31 GPM in C size, 14 to 61 GPM in D size and 42 to 85 GPM in E size. As in our earlier BH\* and V\* vane pump series, cartridge kit design allows easy service when replacement or conversion is needed, reducing the operation to just a few minutes. Cartridge kit design also offer possibilities of quick change of rotation by changing the position of cam ring .

Four different combinations of porting positions are possible in single pumps. In double pumps 32 combinations are possible and 128 for triple pumps.

The high pressure capability of 275 bar in the **DT6 series** reduces installation costs and provides long life at reduced pressure. The high mechanical and volumetric efficiency reduces heat generation and energy consumption. Lower noise levels than most of hydraulic pump designs suppose an advantage and safety for machine operators.

**TDZ** Hydraulics DT series vane pumps are unidirectional but they have been designed for an easy change of rotation. Instructions for change of rotation are included in this catalogue (Instructions for Use and Repair).

### **RECOMMENDED FLUIDS**

Operating characteristics showed in this catalogue have been calculated considering the use of Antiwear petroleum base fluids.

Non Antiwear Petroleum Base Fluids, Synthetic Fluids, Water In Oil Emulsions or Water Glycols are also acceptable. In these cases, speed and pressure limits will be supplied directly by **TDZ** Hydraulics or your nearest distributor.

### **VISCOSITY**

Optimum viscosity for maximum life is between 30 and 40 cSt.

Maximum viscosity is 2000 cSt at very low speed and pressure and 110 cSt at full speed and pressure.

Minimum viscosity is 10 cSt, (18 cSt for fluids other than Antiwear Petroleum Base fluids).

### **FLUID CONTAMINATION AND FILTRATION**

Fluid must be clean during the entire working life of the pump in order to maintain a contamination level of ISO 18/14 or even better, if possible.

Filters with 25 microns are adequate but will not guarantee total cleanliness levels. Suction strainers should be of an adequate size to provide the recommended inlet pressure. For cold starts or fire-resistant fluids, oversize strainers must be used or omitted.

Higher levels of water than 0.10% in mineral oils or 0.05% in synthetic or biodegradable fluids are not acceptable. In these cases, water should be drained off the circuit.

### **FLUID TEMPERATURES**

Fluid viscosity should be selected depending on the normal operating temperature of the unit. Cold starts pump should operate at low pressure and, if possible, low speeds until the fluid warms up to a convenient viscosity for full power application.

### **MINIMUM AND MAXIMUM SPEED**

**Minimum:** 400 rpm.

**Maximum:** 2800 rpm in C series, 2500 rpm in D series and 2200 in E series.

Higher flows of C and D sizes also involves speed limitations, as indicated in the technical chart of this catalogue. Fluids other than Antiwear Petroleum Base fluids will also involve a speed limit, depending on the choice, (consult **TDZ** or your nearest distributor).

## DT6 HYDRAULIC VANE PUMPS

### INTRODUCTION

#### PRESSURE RATINGS

Maximum pressure in **DT6 vane pumps** is 275 bar intermittent for C series and 240 bar for D and E series. Nevertheless, exceptions are indicated in this catalogue when fluids other than Antiwear Petroleum Base are used or in the case of use of high flows of C and D pump sizes.

Both continuous and intermittent pressures are indicated in this catalogue. The maximum period of intermittent pressure may be considered acceptable when the average pressure time is less than or equal to the continuous recommended pressure, for that particular model during a complete cycle of work.

#### MINIMUM INLET PRESSURE

Minimum allowable inlet pressure is 0.95 bar for 1,800 rpm or less, 1.10 bar between 1,800 and 2,300 rpm and 1.30 bar when the speed is more than 2,300 rpm.

Multiply the above-mentioned values by 1.40 when fluids other than Antiwear Petroleum base fluids are used.

The difference between inlet pressure and atmospheric pressure should not exceed 0.2 bar to prevent aeration. Inlet Pressure is considered with petroleum base fluids at viscosities of between 10 and 65 cSt.

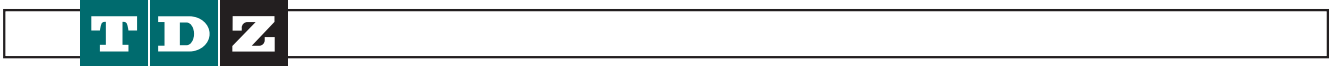

hydraulics



# **SINGLE VANE PUMPS**

BH\*, V\* and DT6 single vane pumps

**BH\* SINGLE VANE PUMP ORDERING CODE**

F3	BHQ	4	67	D	1	A	00
1	2	3	4	5	6	7	8

**1 - "F3"** means special seals for fire-resistant fluids. Omit if not required.

**2 - Pump Type:**

**BHP = 10 vane pump**, industrial and mobile use, BSP, NPT & SAE threads.

**BHS = 12 vane pump**, industrial use (very quiet), metric threads.

**BHQ = 10 vane pump and bronze plates**, mobile use, metric threads.

**3 - Pump model:** 1, 2 and 3 in BHP types; 4, 6 and 7 in BHS and BHQ types.

**4 - Flow:** BHP, BHS and BHQ in Litres per minute at 1000 rpm and 7 Bar.

**5 - D = Right-hand** direction of rotation (Clockwise).

**Y = Left-hand** direction of rotation.

(To check the direction of rotation view from the shaft end).

**6 - Shaft type:** See on each pump model.

**7 - Outlet position, (viewed from shaft):**

A: Outlet in line with inlet.

B: 90° on the right from inlet (Clockwise from inlet).

C: 180° from inlet.

D: 90° on the left from inlet (90° counterclockwise from inlet).

**8- Special characteristics**

Omit if not required.

Example: 02 : BSP

03 : UNF

04 : NPT

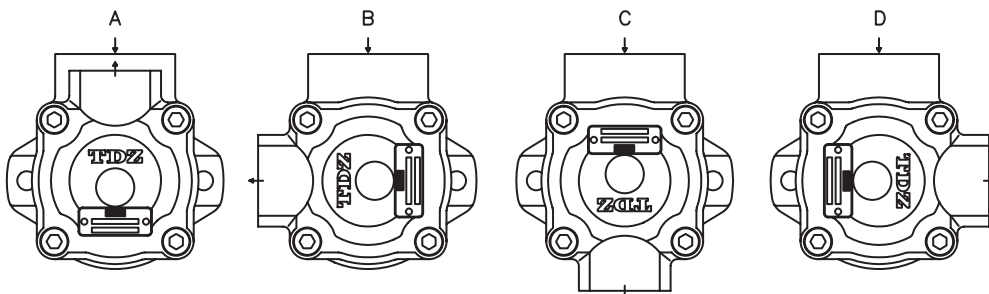

**BH\* SINGLE VANE PUMP CHARACTERISTICS**

**TDZ DESIGN VANE PUMPS**

TYPE	FLOW			SPEED (rpm)		PRESSURE (Bar)		Nominal Power (3)	CONNECTION		WEIGHT (Kgs.)								
	Lts.at 1000 rpm	Gal. At 1200 rpm	Reduction (2)	Min.	Max.	Contin.	Intermit.		Inlet	Outlet									
<b>BHP1</b>	2	0,6	0,18	600	2500	150	175	0,5	(4)	(4)	1								
	3	0,9	0,18					0,7											
	4,5	1,2	0,36					1											
	5,5	1,7	0,36					1,4											
	6,5	2	0,36					1,6											
<b>BHP2 (1)</b>	7	2,2	0,7	600	2500	150	175	1,8	(4)	(4)	3,6								
	8	2,5	1,1					2											
	10	3,2	1,1					2,5											
	12	3,8	1,1					3											
	15	4,7	1,1					3,7											
<b>BHP3</b>	6	2	0,9	600	2500	150	175	1,9	(4)	(4)	7,1								
	16	5	1,7					4,3											
	18	6	2,8					5,3											
	25	8	4,5					6,9											
	27	9	4,8					7,6											
	35	11	4,8					8,8											
	38	12	5,4					10,2											
	44	14	6,6					11,9											
	50	16	7,8					13,6											
	<b>BHS4 BHQ4</b>	26	8					4,5				600	2500 1800 (BHS)	175	210	6,9	Ø38	Ø26	14,5
40		12	5,7	10,4															
45		14	5,7	11,6															
55		17	5,8	13,8															
60		19	5,8	14,6															
67		21	6	16,8															
80		24	6,2	20,3															
88*		27*	6,5	22,4															
<b>BHS6 BHQ6</b>		66	21	8,6	600	2400 1800 (BHS)	175	210	16,8	Ø60	Ø32					26,3			
		81	25	9					20,3										
	97	30	10	24,3															
	112	35	11,4	27,4															
	121	38	11,4	29,3															
	142	45	13,1	33,3															
	<b>BHS7 BHQ7</b>	138	42	15					600			2200 1800 (BHS)	155	175	32,3		Ø75	Ø38	38,3
		148	47	15,7											36,3				
		162	50	14,3											37,9				
		180	57	17,9											43,2				
193		60	18,6	46,1															
214		67	22	51,2															
240		75	26	57,4															

\* 27 gallons (88 lts.) cartridge not mounted in BHQ4 vane pump model.

(1) There is a version of this pump with built-in flow regulating and pressure limiter valves, ref. B2V. If a built-in tank with filter is required, the ref. Is **B2VC** (1.5 ltrs. tank) or **B2VA** (1 litre tank).

(2) **Delivery flow reduction** in Ltrs./min. at 100 Bar. 22 cST of oil viscosity at operating temperature. To calculate the approximate delivery flow at a given pressure and speed, use the following formula with flow reduction and theoretical flow values shown in the chart. Flow reduction values are independent of shaft speed.

$$\text{Approx. output flow (Ltrs./min.)} = \text{Theoretical flow} \times \frac{\text{R.P.M}}{1000} - \text{Reduction} \times \frac{\text{Pressure (Bar)}}{1000}$$

(3) **Nominal power** in H.P. at 100 Bar and 1000 RPM (to convert into Kw multiply by 0.735). To obtain the real input power at different pressure and revolutions, use the formula as follows:

$$\text{Real input power} = \text{Input power} \times \frac{\text{R.P.M}}{1000} \times \frac{\text{Pressure (Bar)}}{1000}$$

(4) See options on dimension pages.

**SINGLE VANE PUMP TYPE BHP-1**

FLOW						SPEED (rpm)		PRES (BAR)		CONNECTION		WEIGHT
Lts at 1000 rpm	2	3	4,5	5,5	6,5	Mín.	Máx.	Contin.	Intermit.	Inlet	Outlet	(Kgs.)
Gal at 1200 rpm	0,6	0,9	1,2	1,7	2	600	2500	175	210	Ø38	Ø26	14,5

DIMENSIONS IN MILLIMETRES 1" = 25.4 millimetres

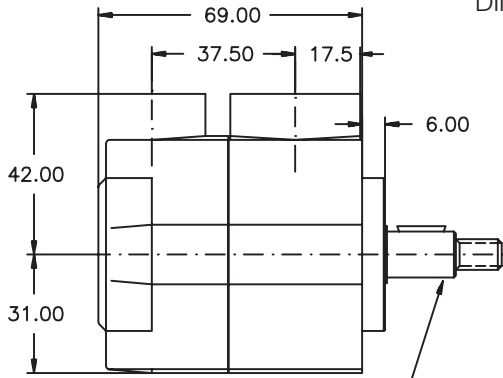

See shaft types and measures

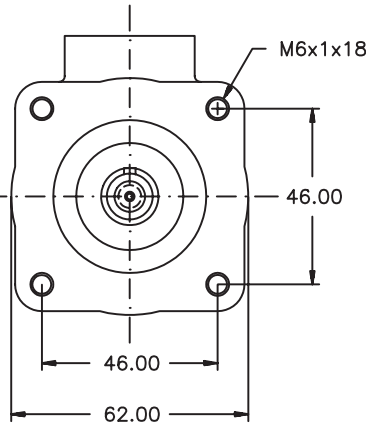

**N°1 Shaft**

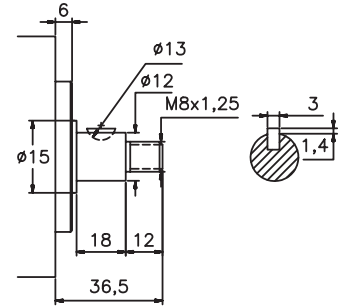

**N°2 Shaft**

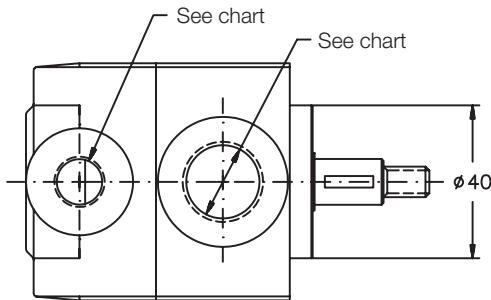
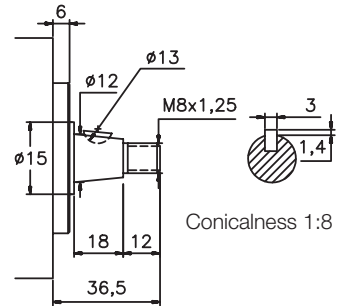

Num.	Inlet	Outlet
01	1/2" BSP	1/4" BSP
02	3/8" BSP	1/4" BSP

**BHP1 PUMP AND FRAME SET TO CONNECT TO ELECTRIC MOTOR**

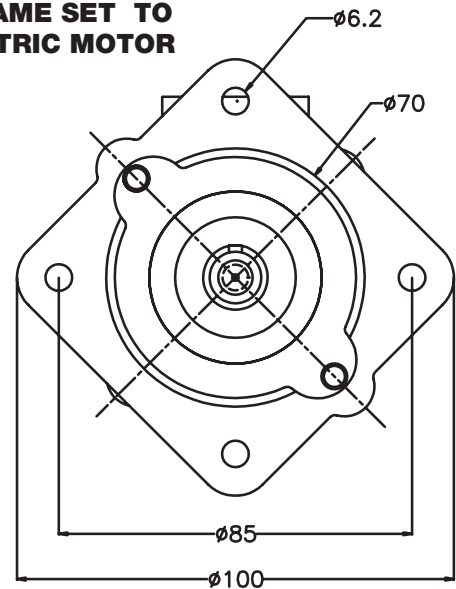
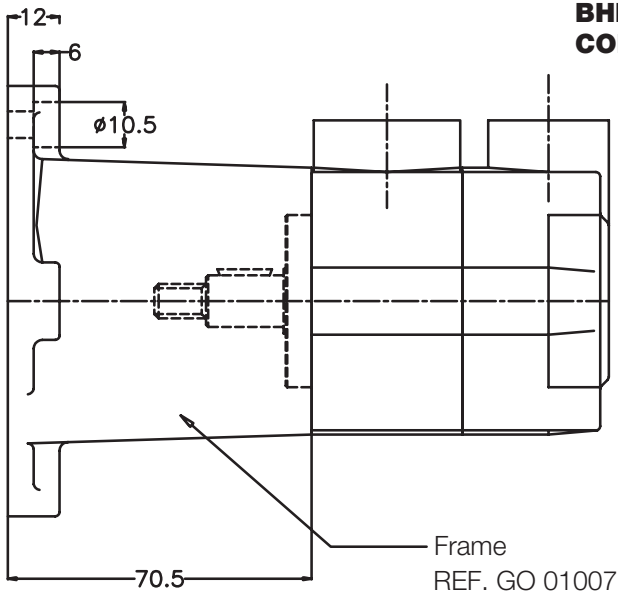

**SINGLE VANE PUMP TYPE BHP-1**

**FLOW AND INPUT POWER DIAGRAMS**

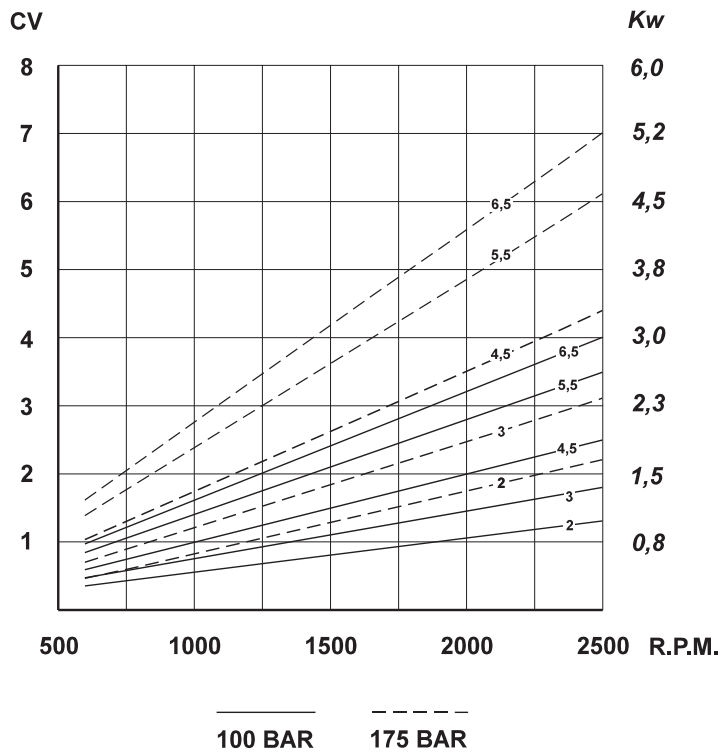
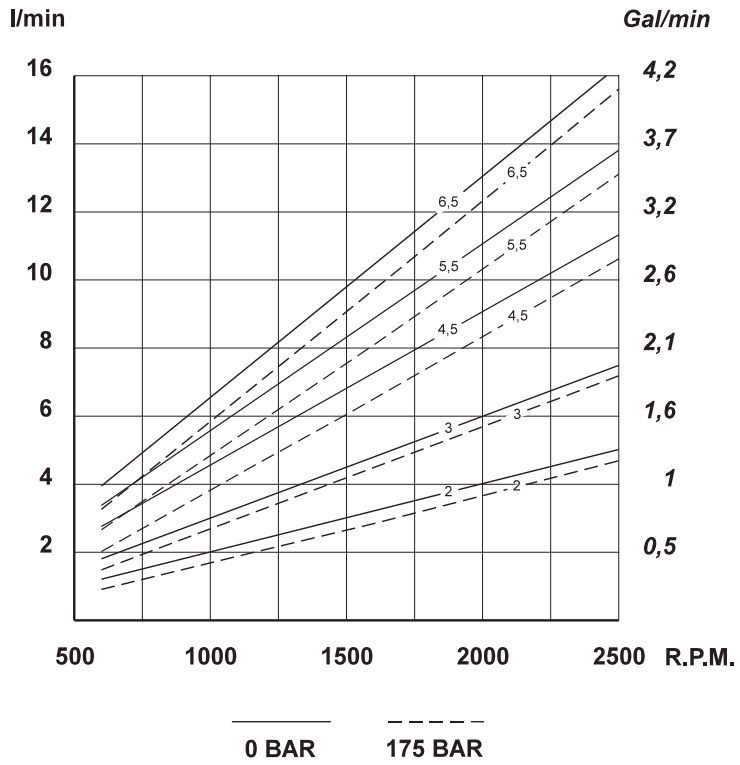

**SINGLE VANE PUMP TYPE BHP-2**

FLOW						SPEED (rpm)		PRES (BAR)		CONNECTION		WEIGHT (Kgs.)
Lts at 1000 rpm	7	8	10	12	15	Mín.	Máx.	Contin.	Intermit.	Inlet	Outlet	
Gal at 1200 rpm	2,2	2,5	3,2	3,8	4,7	600	2500*	150	175	3/4" BSP	1/2" BSP	3,6

\* For further details see general chart

DIMENSIONS IN MILLIMETRES 1" = 25.4 millimetres

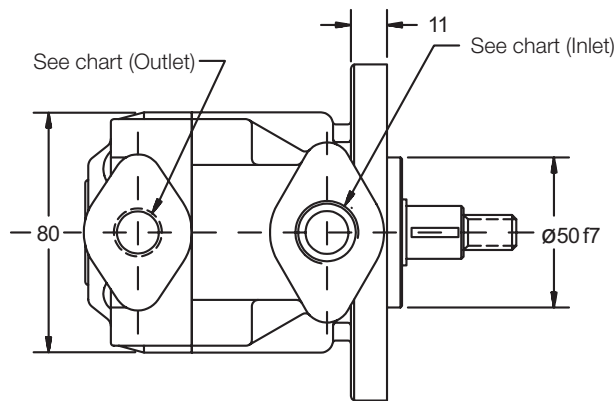
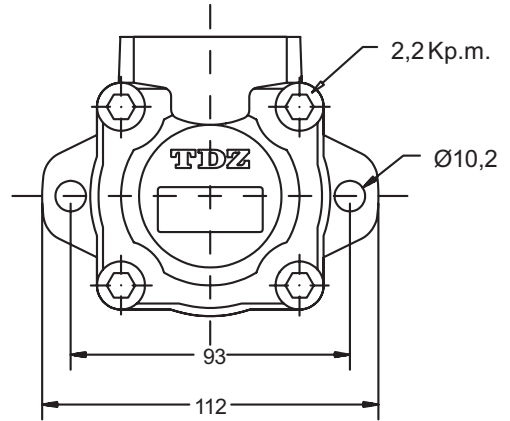
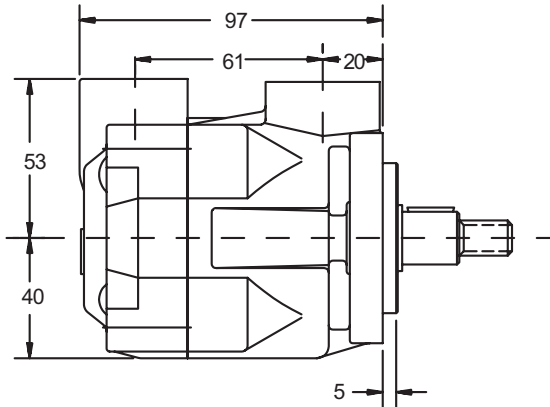

Num.	Inlet	Outlet
02	3/4" BSP	1/2" BSP

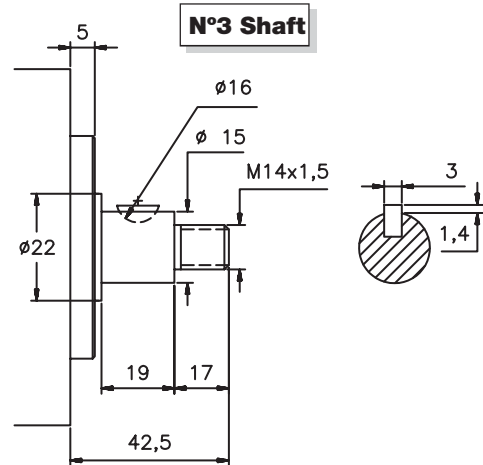
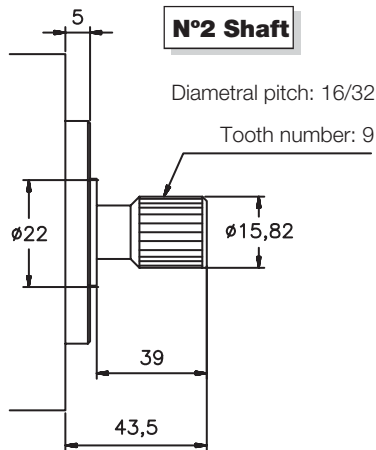
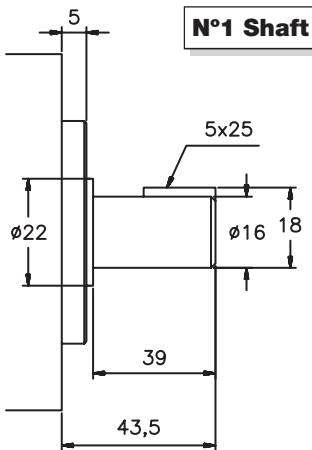

Enquire about other types of shafts

**SINGLE VANE PUMP TYPE BHP-2**

**FLOW AND INPUT POWER DIAGRAMS**

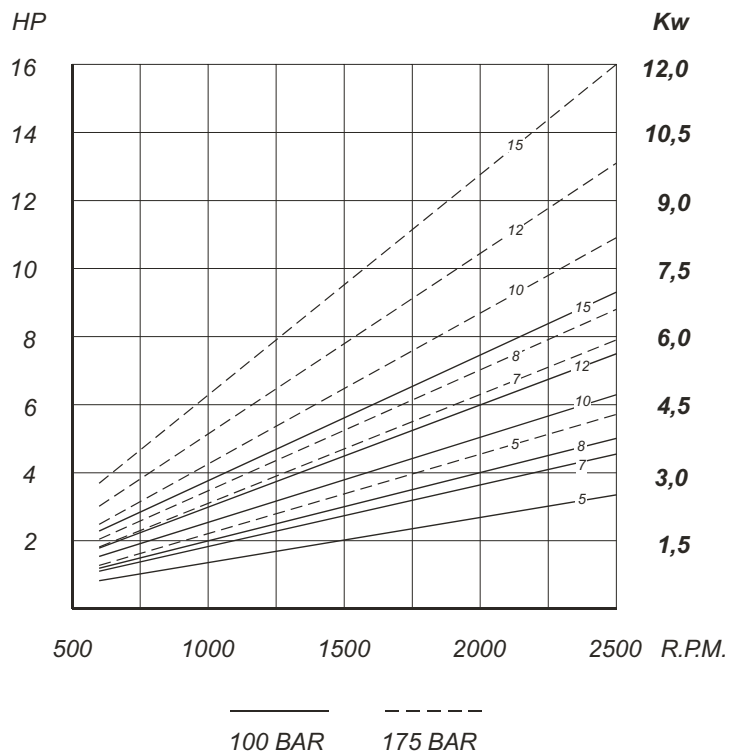
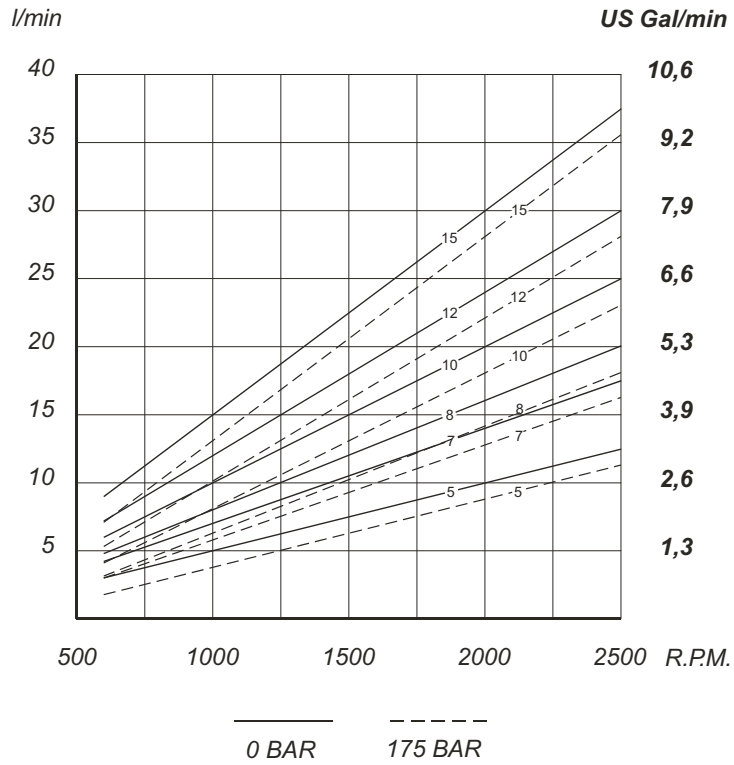

**SINGLE VANE PUMP TYPE BHP-3**

FLOW										SPEED (rpm)		PRES (BAR)		CONNECTION		WEIGHT (Kgs.)
										Min.	Max.	Contin.	Intermit.	Inlet	Outlet	
Lts at 1000 rpm	6	16	18	25	27	35	38	44	50	600	2500*	150	175	1" BSP	3/4" BSP	7,1
Gal at 1200 rpm	2	5	6	8	9	11	12	14	16							

\* For further details see general chart See chart below for additional connections

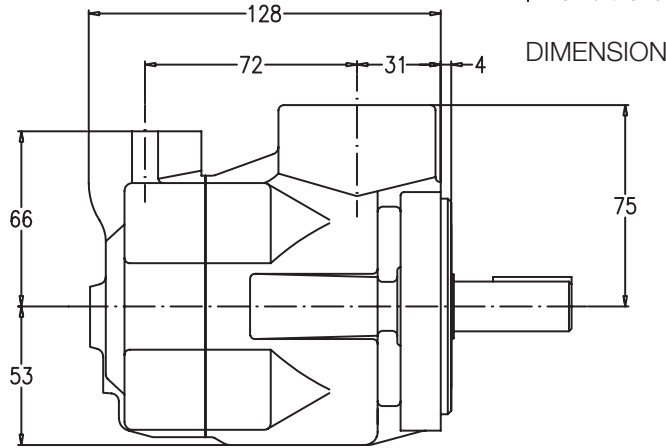

DIMENSIONS IN MILLIMETRES 1" = 25.4 millimetres

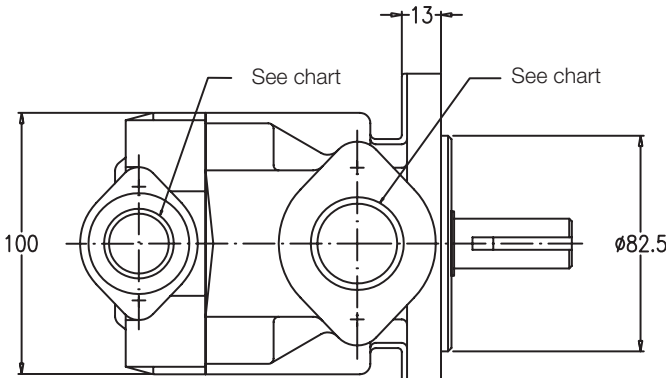
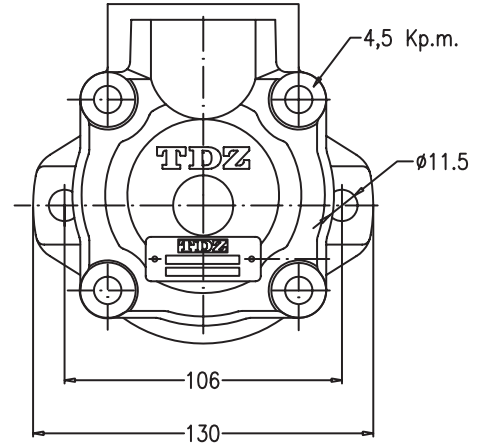

Standard version.(SAE flange)

Num.	Inlet	Outlet
01	1" BSP	3/4" BSP
02	1" 1/4 BSP	3/4" BSP
03	1" 5/8 UNF	1" 1/16 UNF
04	1" 1/4 NPT	3/4" NPT

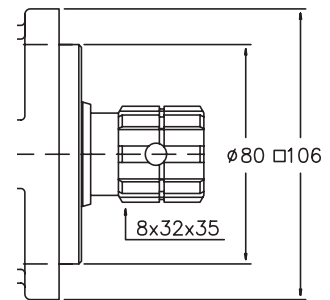
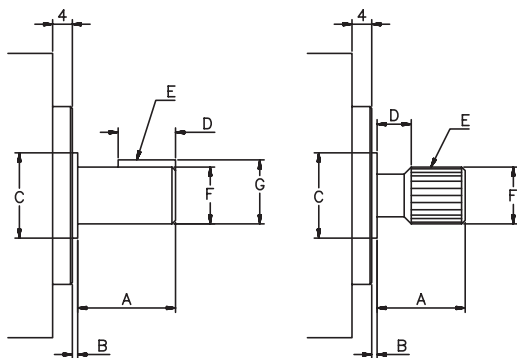

Version for direct mounting in Power Take-Off (ISO flange)

	Parallel shaft	
	N° 1	N° 6
A	45	62.5
B	2	1
C	Ø25	Ø25
D	30	41
E	5	4,75
F	Ø19	Ø19
G	21,1	21,1

	Splined shaft		
	N° 2	N° 4	N° 5
A	47	30	24,5
B	1	1	1
C	Ø25	Ø25	Ø25
D	15	4	3,5
F	Ø21,80	Ø17,1	Ø15,82

Shaft	E
N° 2	Diametral pitch 16/32 Teeth:13
N° 4	DIN 5482 B18x15 Teeth:10
N° 5	Diametral pitch 16/32 Teeth:9



**SINGLE VANE PUMP TYPE BHP-3**

**FLOW AND INPUT POWER DIAGRAMS**

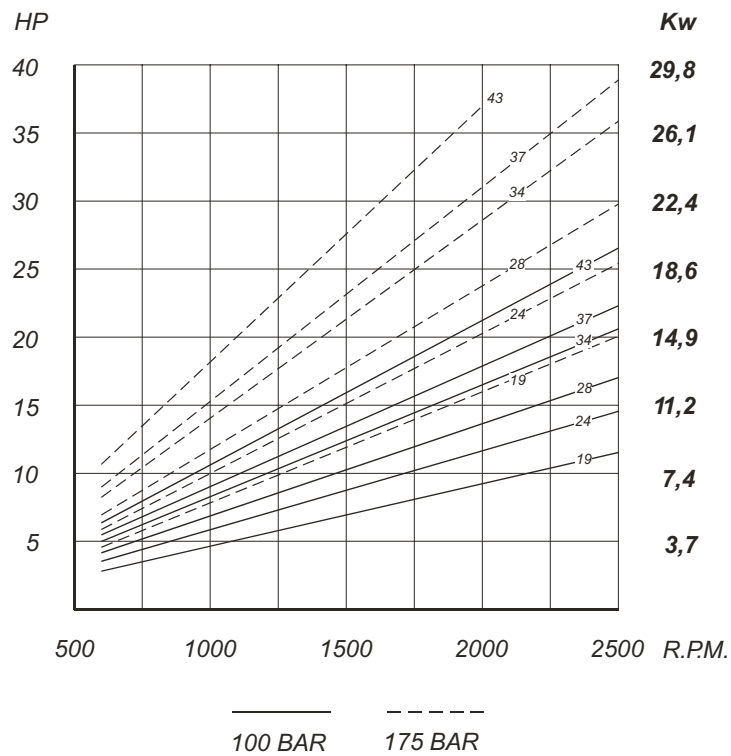
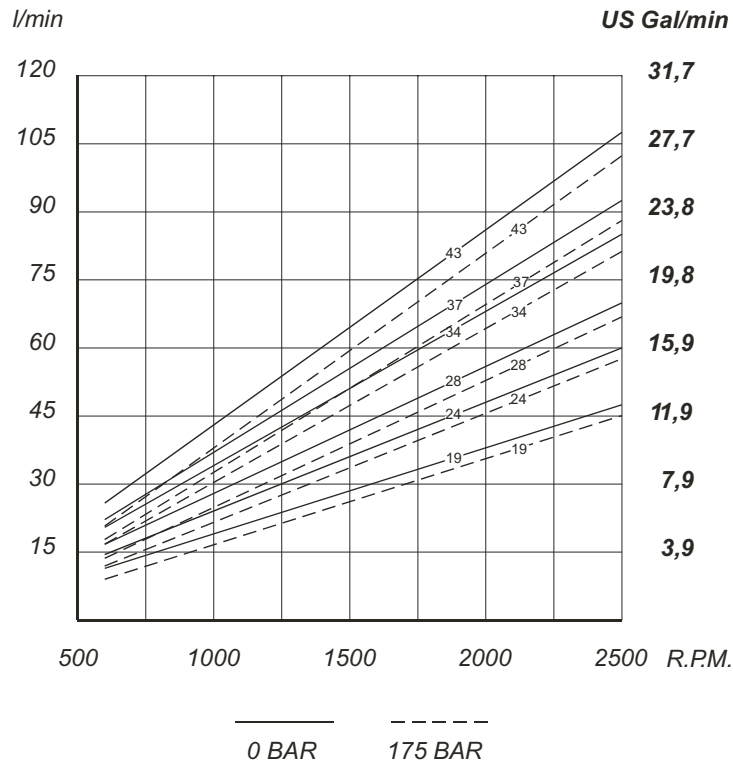

**SINGLE VANE PUMP TYPE BHS-4 & BHQ-4**

FLOW								SPEED (rpm)		PRES (BAR)		CONNECTION		WEIGHT (Kgs.)	
Lts at 1000 rpm	26	39	44	54	60	66	80*	85*	Mín.	Máx.	Contin.	Intermit.	Inlet		Outlet
Gal at 1200 rpm	8	12	14	17	19	21	24*	27*	600	2500*	175	210*	Ø38	Ø26	14,5

\* For further details see general chart

DIMENSIONS IN MILLIMETRES 1" = 25.4 millimetres

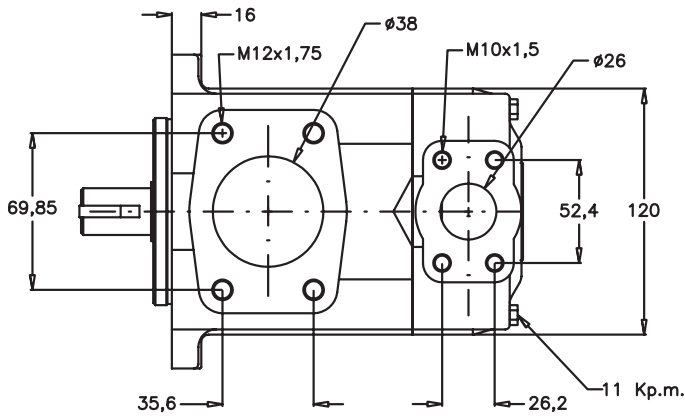
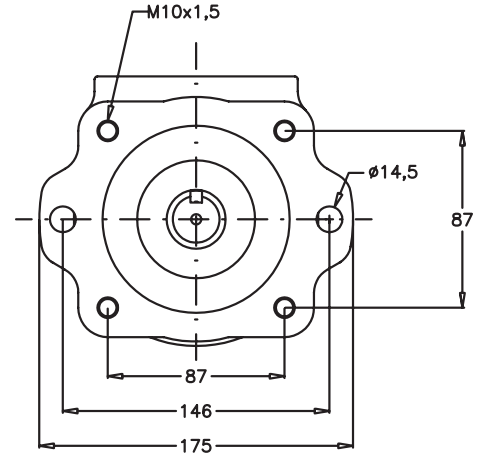
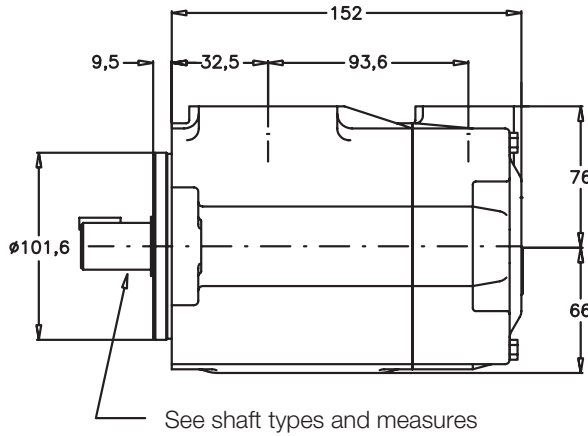

**N°1 Shaft**

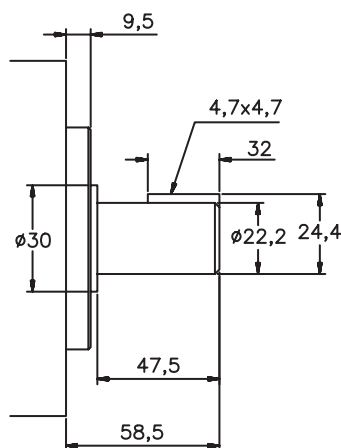

**N°2 Shaft**

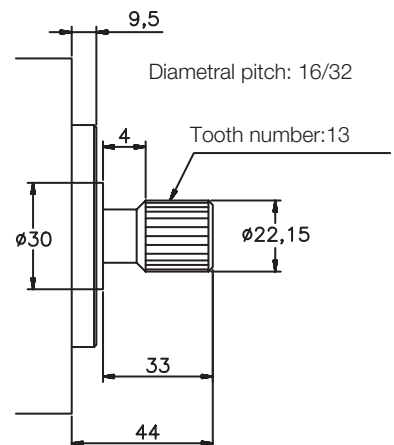

Enquire about other types of shafts

**SINGLE VANE PUMP TYPE BHS-4 & BHQ-4**

**FLOW AND INPUT POWER DIAGRAMS**

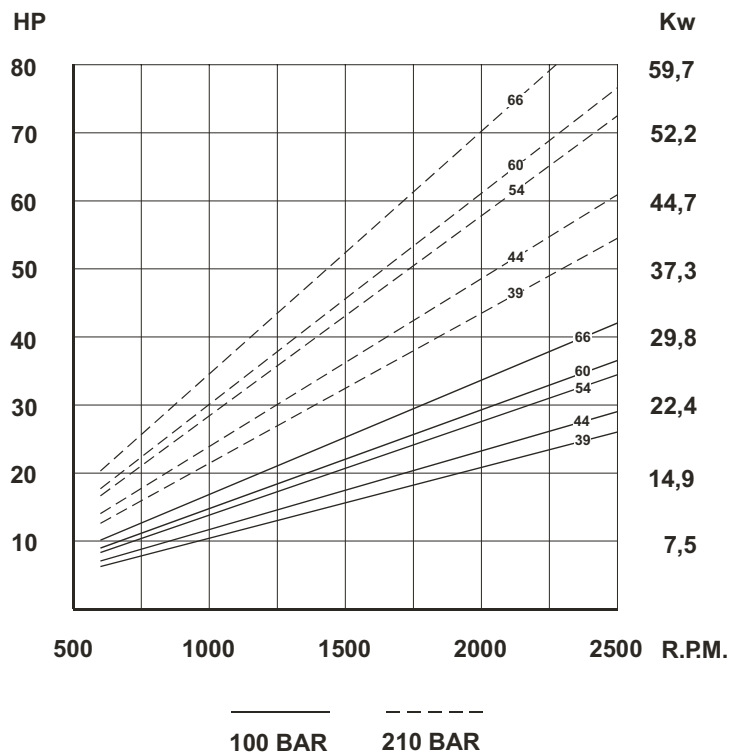
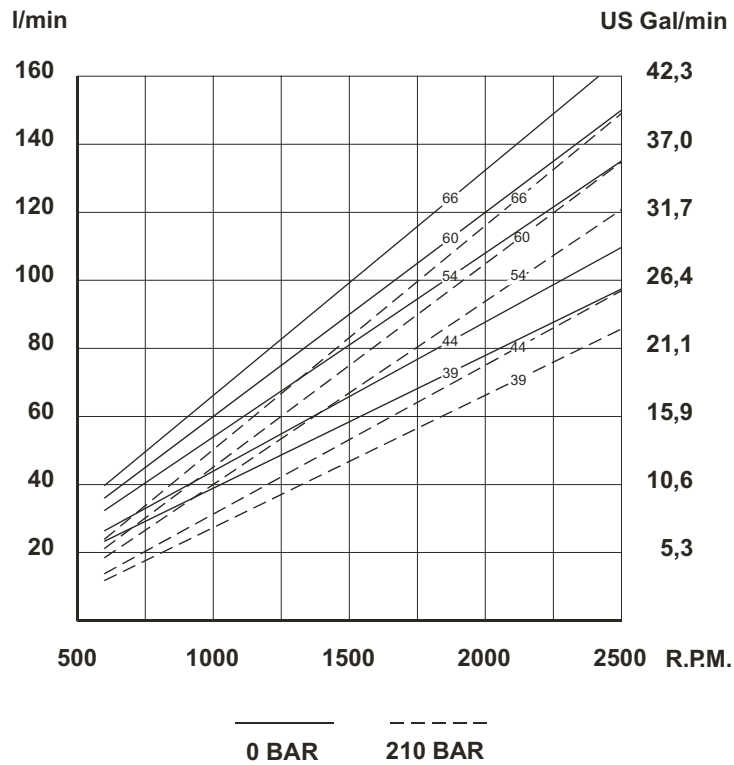

**SINGLE VANE PUMPS**

**SINGLE VANE PUMP TYPE BHS-6 & BHQ-6**

FLOW						SPEED (rpm)		PRES (BAR)		CONNECTION		WEIGHT (Kgs.)	
Lts at 1000 rpm	66	81	97	112	121	142*	Min.	Máx.	Contin.	Intermit.	Inlet		Outlet
Gal at 1200 rpm	21	25	30	35	38	45*	600	2400*	175	210*	Ø60	Ø32	26,3

\* For further details see general chart

DIMENSIONS IN MILLIMETRES 1" = 25.4 millimetres

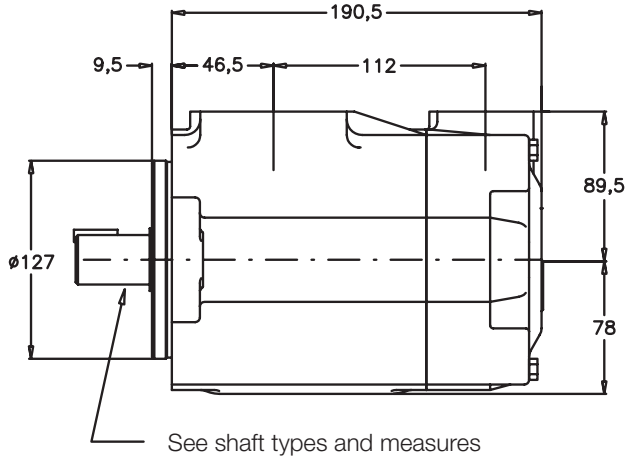

See shaft types and measures

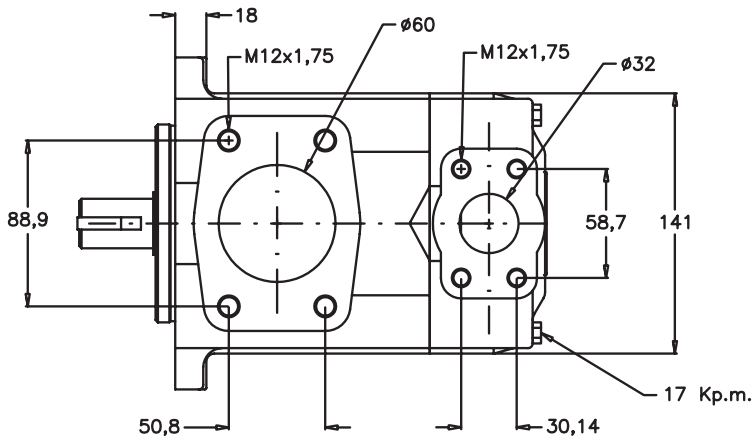
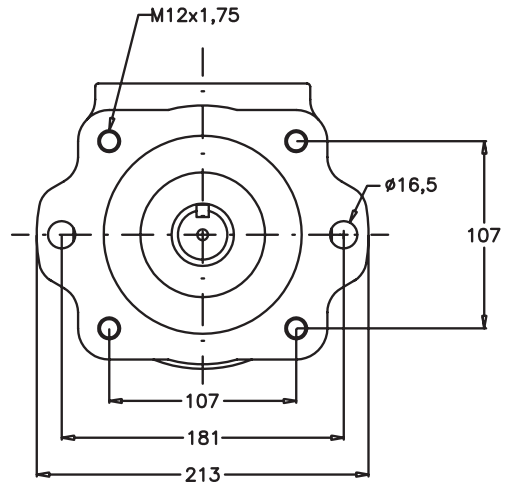

**N°1 Shaft**

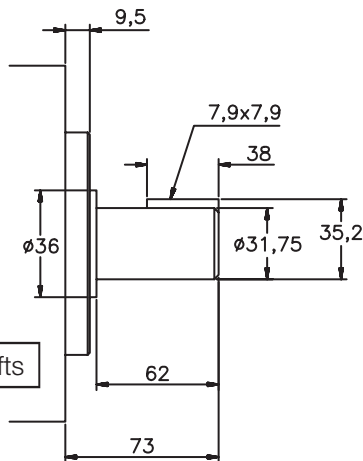

**N°2 Shaft**

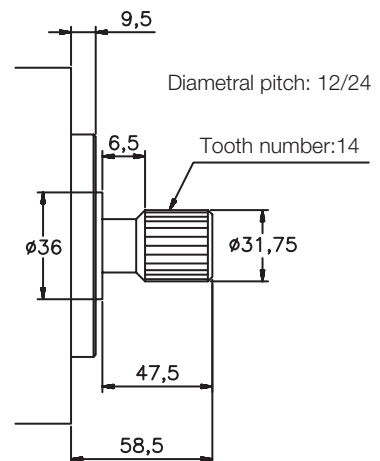

Enquire about other types of shafts

**SINGLE VANE PUMP TYPE BHS-6 & BHQ-6**

**FLOW AND INPUT POWER DIAGRAMS**

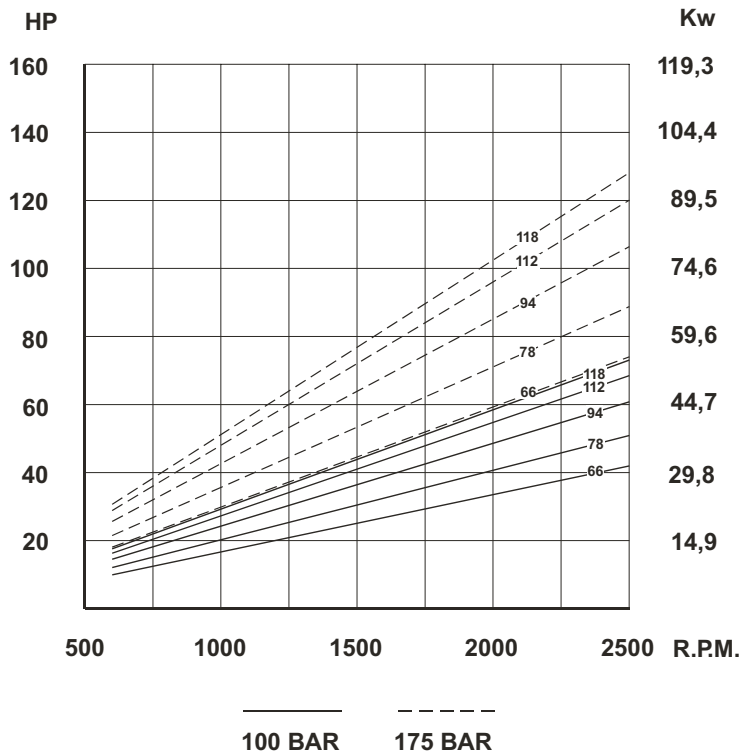
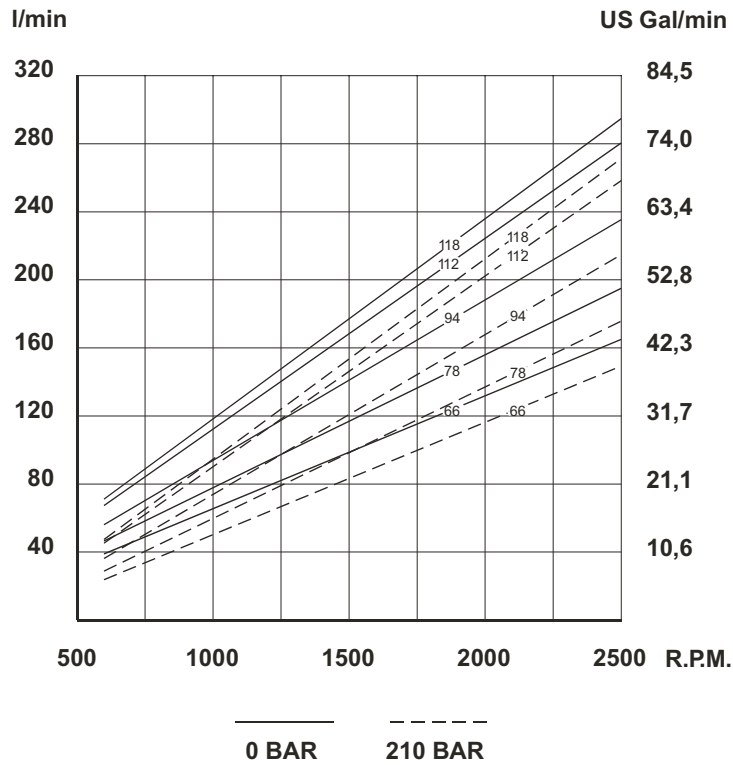

**SINGLE VANE PUMP TYPE BHS-7 & BHQ-7**

FLOW	SPEED (rpm)		PRES (BAR)		CONNECTION		WEIGHT (Kgs.)
	Min.	Máx.	Contin.	Intermit.	Inlet	Outlet	
Lts at 1000 rpm 138 148 162 180 193 214 240	600	2200*	155	175	Ø75	Ø38	38,3
Gal at 1200 rpm 42 47 50 57 60 67 75							

\* For further details see general chart

DIMENSIONS IN MILLIMETRES 1" = 25.4 millimetres

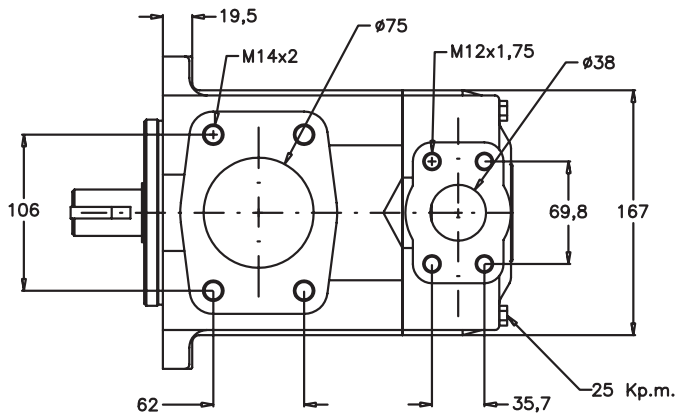
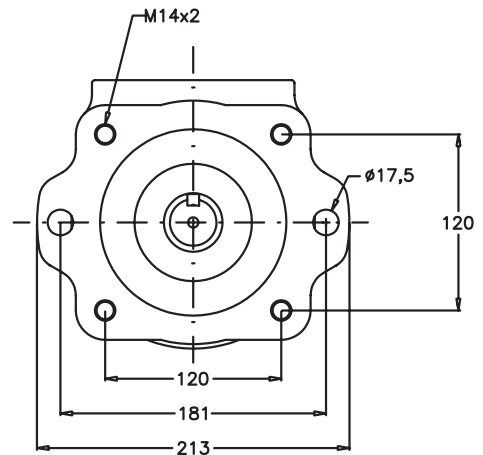
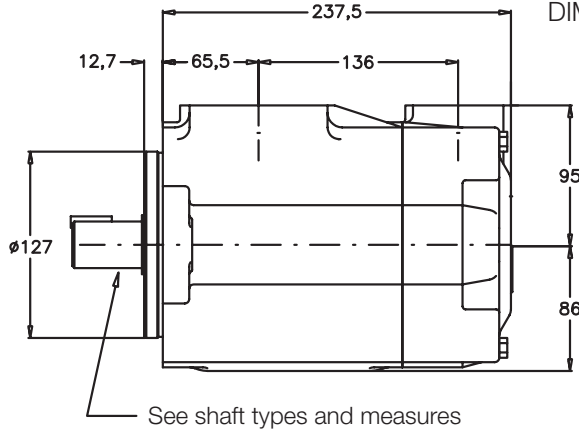

**N°1 Shaft**

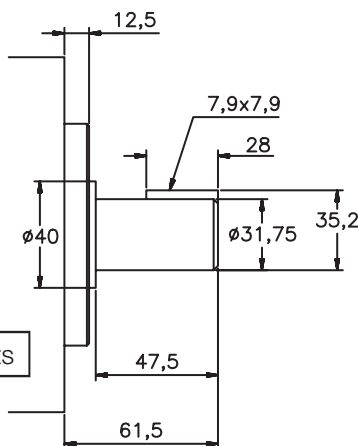

**N°2 Shaft**

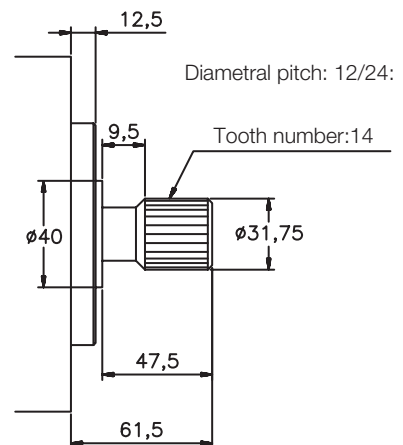

Enquire about other types of shafts

**SINGLE VANE PUMP TYPE BHS-7 & BHQ-7**

**FLOW AND INPUT POWER DIAGRAMS**

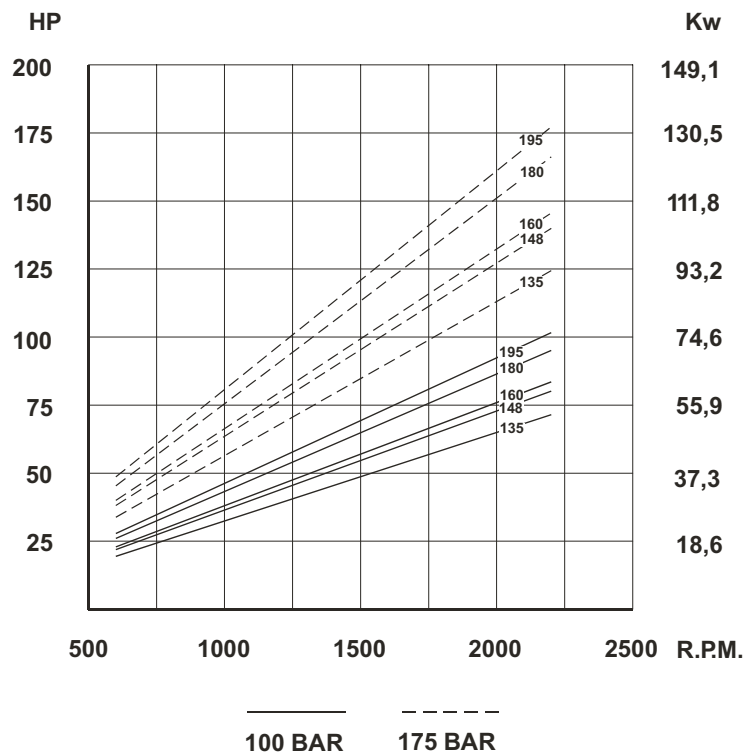
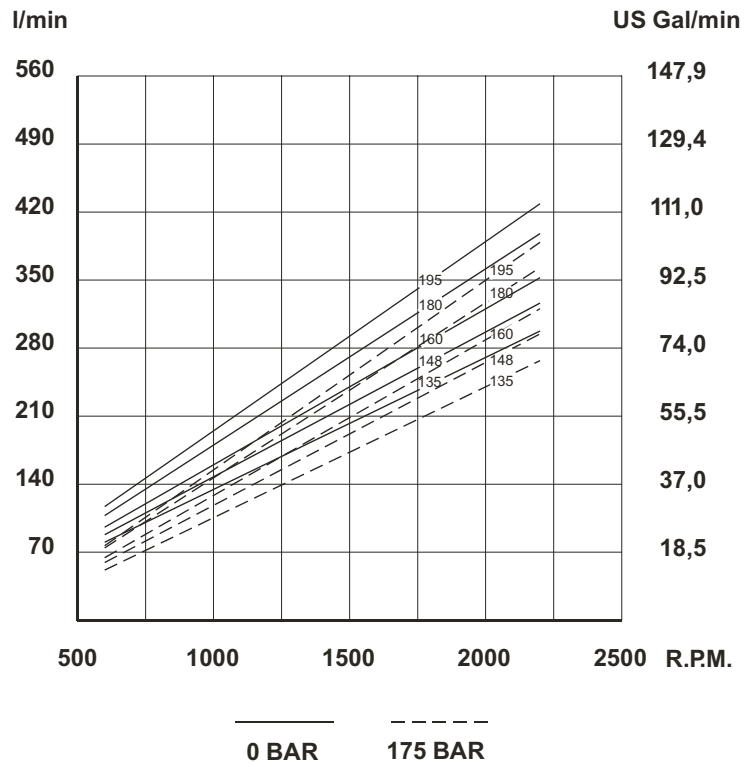

## V\* SINGLE VANE PUMP ORDERING CODE

F3	VS	25	67	D	1	A	00
1	2	3	4	5	6	7	8

**1 - "F3"** means special seals for fire-resistant fluids. Omit if not required.

**2 - Pump Type:**

**VK = 10 vane pump**, mobile and industrial use, UNC threads.

**VS = 12 vane pump**, industrial use (very quiet), UNC threads.

**VQ = 10 vane pump and bronze plates**, mobile use, UNC threads

**3 - Pump model:** VC10, VC20; 20, 25, 35 and 45 in VS and VQ types.

**4 - Flow:** VC, VS and VQ in US Gallons per minute at 1200 rpm and 7 Bar.

**5 - D = Right-hand** direction of rotation (Clockwise).

**Y = Left-hand** direction of rotation.

(To check the direction of rotation view from the shaft end).

**6 - Shaft type:** See on each pump model.

**7 - Outlet position, (viewed from shaft):**

A: Outlet in line with inlet.

B: 90° on the right from inlet (Clockwise from inlet).

C: 180° from inlet.

D: 90° on the left from inlet (90° counterclockwise from inlet).

**8- Special characteristic**

Omit if not required

Example: 02 : BSP

03 : UNF

04 : NPT

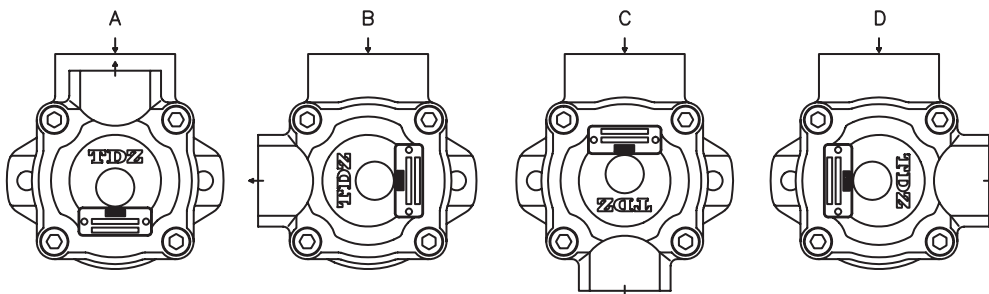



# SINGLE VANE PUMP CHARACTERISTICS

## VICKERS DESIGN VANE PUMPS

TYPE	FLOW			SPEED (rpm)		PRESSURE (Bar)		Nominal Power (3)	CONNECTION		WEIGHT (Kgs.)	
	Lts.at 1000 rpm	Gal.at 1200 rpm	Reduction (2)	Min.	Máx.	Contin.	Intermit.		Inlet	Outlet		
<b>VC10</b>	3	1	0,8	600	4800	155	180	0,7	(4)	(4)	4,5	
	6	2	0,9		4500							
	9	3	1,2		4000							
	13	4	1,6		3400							
	16	5	1,7		3200							
	19	6	1,8		3000							
	22	7	1,9		2800							
<b>VC20 (1)</b>	19	6	2,8	600	3400	155	180	3,9	(4)	(4)	7,3	
	22	7	4,2		3000							
	26	8	4,5		2800							
	29	9	4,8		2800							
	36	11	4,8		2500							
	39	12	5,4		2400							
	42	13	6,0		2400							
<b>VK20 VQ20</b>	8	2	0,9	600	1800	175	210	1,9	Ø1½"	Ø3/4"	12	
	18	5	2,1									4
	27	8	2,8									6,6
	29	9	3,5									6,9
	36	11	4,3									7,3
	39	12	4,3									7,4
	46	14	5,3									7,6
<b>VS25 VQ25</b>	26	8	4,5	600	2500 1800 (VS)	175	210	6,9	Ø1½"	Ø1"	15	
	40	12	5,7									10,4
	45	14	5,7									11,6
	55	17	5,8									13,8
	60	19	5,8									14,6
	67	21	6									16,8
	80	24	6,2									20,3
88*	27	6,5	21,1									
<b>VS35 VQ35</b>	66	21	8,6	600	2400 1800 (VS)	175	210	16,8	Ø2"	Ø1¼"	23	
	81	25	9									20,3
	97	30	10									24,3
	112	35	11,4									27,4
	121	38	11,4									29,3
	142	45	13,1									33,3
<b>VS45 VQ45</b>	138	42	15	600	2200 1800 (VS)	155	175	32,3	Ø3"	Ø1½"	35,5	
	148	47	15,7									36,3
	162	50	14,3									37,9
	180	57	17,9									43,2
	193	60	18,6									46,1
	214	67	22									51,2
	240	75	26									57,4

\* 27 gallons (88 lts.) cartridge not mounted in BQ25 vane pump model.

(1) There is a version of this pump with built-in flow regulating and pressure limiter valves, ref. VC20F.

(2) **Delivery flow reduction** in Ltrs./min. at 100 Bar. 22 cST of oil viscosity at operating temperature. To calculate the approximate delivery flow at a given pressure and speed, use the following formula with flow reduction and theoretical flow values shown in the chart. Flow reduction values are independent of shaft speed.

$$\text{Approx. output flow (Ltrs./min.)} = \text{Theoretical flow} \times \frac{\text{R.P.M.}}{1000} - \text{Reduction} \times \frac{\text{Pressure (Bar)}}{1000}$$

(3) **Nominal power** in H.P. at 100 Bar and 1000 RPM (to convert into Kw multiply by 0.735).

To obtain the real input power at different pressure and revolutions, use the formula as follows:

$$\text{Real input power} = \text{Input power} \times \frac{\text{R.P.M.}}{1000} \times \frac{\text{Pressure (Bar)}}{100}$$

(4) See options on dimension pages.

**SINGLE VANE PUMP TYPE VC-10**

FLOW			SPEED (rpm)		PRESSURE (Bar)		Nominal Power (3)	CONNECTION		WEIGHT (Kgs.)
Lts.at 1000rpm	Gal.at 1200rpm	Reduction (2)	Mín.	Máx.	Contin.	Intermit.		Inlet	Outlet	
3	1	0,8	600	4800	155	180	0,7	1" NPT	1/2" NPT	4,5
6	2	0,9		4500						
9	3	1,2		4000						
13	4	1,6		3400						
16	5	1,7		3200						
19	6	1,8		3000						
22	7	1,9		2800						
					140	4,2				

(2) & (3) see page 27.

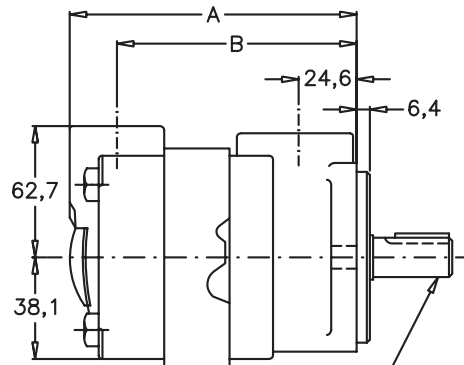
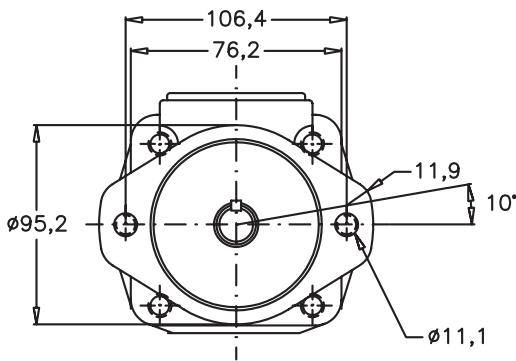

See shaft types and measures

Gallons	Dimension	
	A	B
1, 2, 3	115,6	91,9
4, 5	121,9	98,3
6, 7	127	103,4

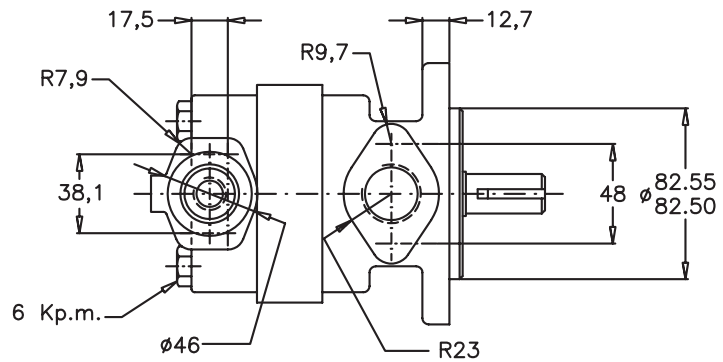

Num.	Inlet	Outlet
02	1" BSP	1/2 BSP
04	1" NPT	1/2" NPT

**N°1 Shaft**

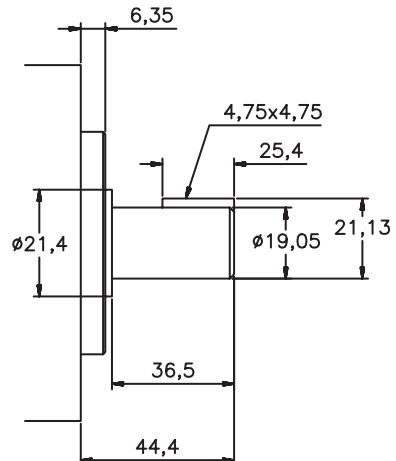

Contact **TDZ** or your nearest distributor for other shaft types

**SINGLE VANE PUMP TYPE VC-10**



**FLOW AND INPUT POWER DIAGRAMS**

-----  
Max. pressure (180 bar)  
-----  
Pressure (7 bar)

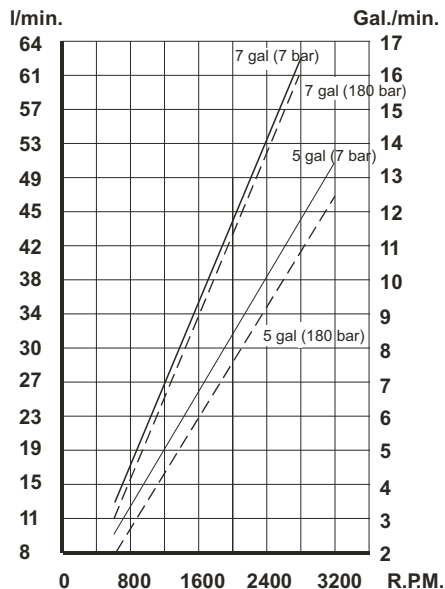
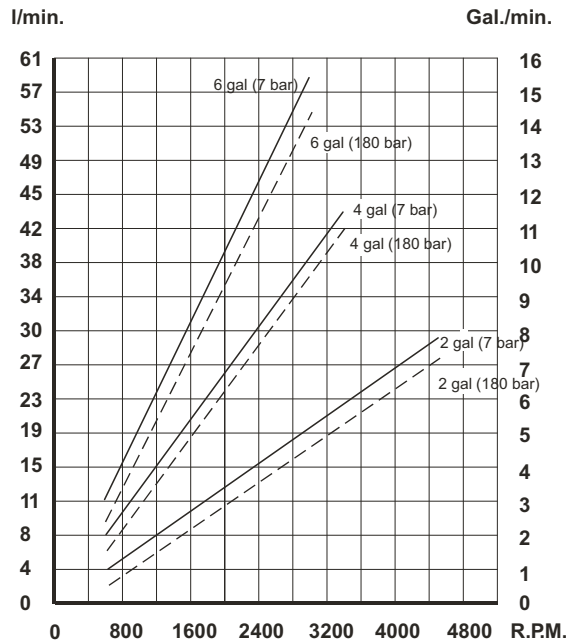
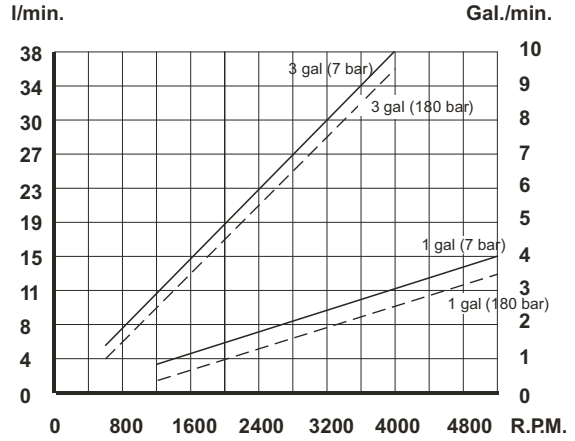
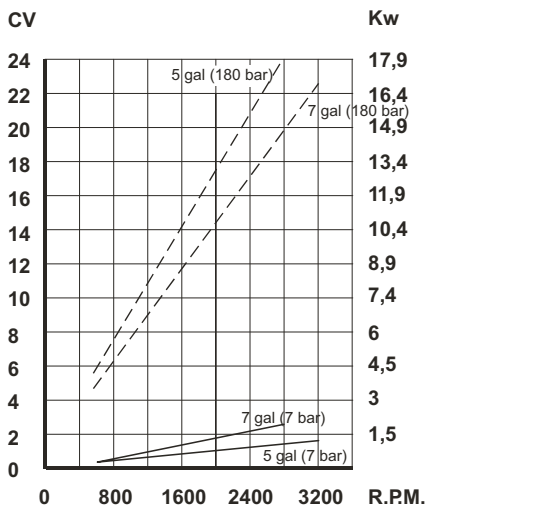
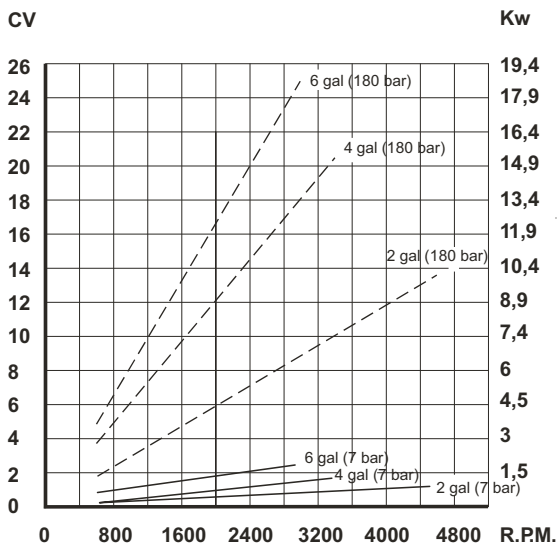
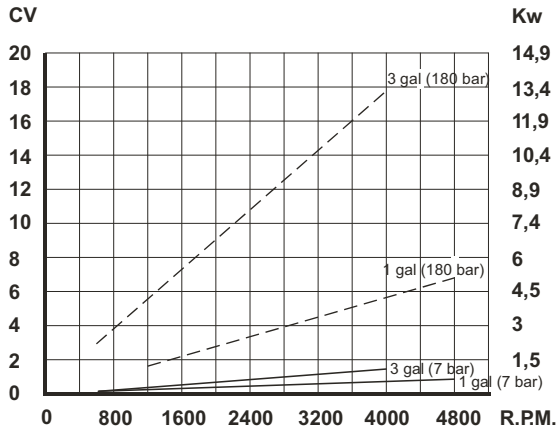

**SINGLE VANE PUMP TYPE VC-20**

FLOW			SPEED (rpm)		PRES (BAR)		Nominal Power (3)	CONNECTION		WEIGHT (Kgs.)
Lts.at 1000rpm	Gal.at 1200rpm	Reduction (2)	Min.	Max.	Contin.	Intermit.		Inlet	Outlet	
19	6	2,8	600	3400	155	180	3,9	1 1/4" NPT	3/4" NPT	7,3
22	7	4,2		3000						
26	8	4,5		2800						
29	9	4,8		2800						
36	11	4,8		2500						
39	12	5,4		2400						
42	13	6,0		2400			140			

(2) & (3) see page 27.

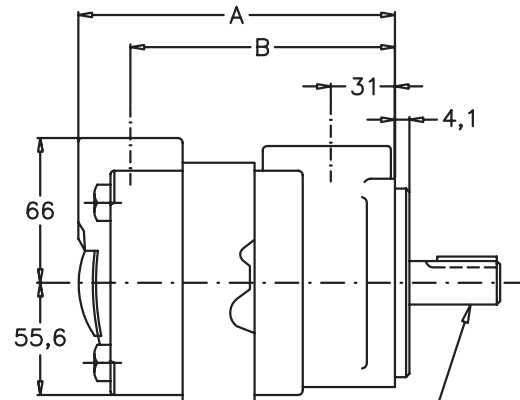
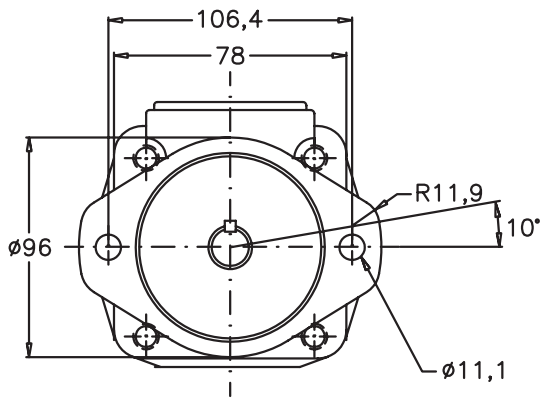

See shaft types and measures

Galon	Dimension	
	A	B
6	125,2	102,1
7, 8, 9	131,6	108,4
11	136,7	113,5
12, 13	140,2	117,1

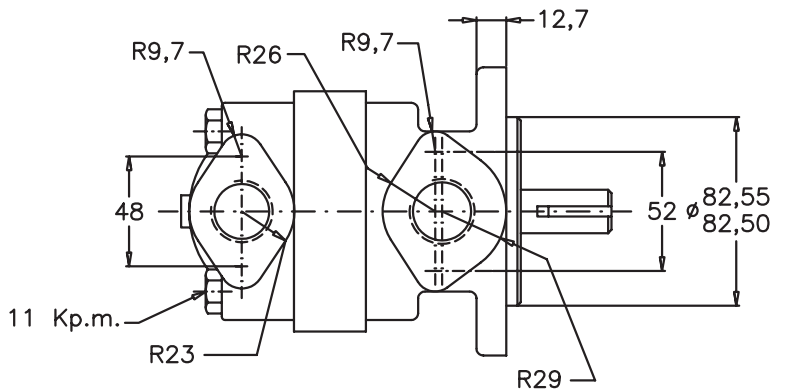

Num.	Inlet	Outlet
02	1" 1/4 BSP	3/4" BSP
04	1" 1/4 NPT	3/4" NPT

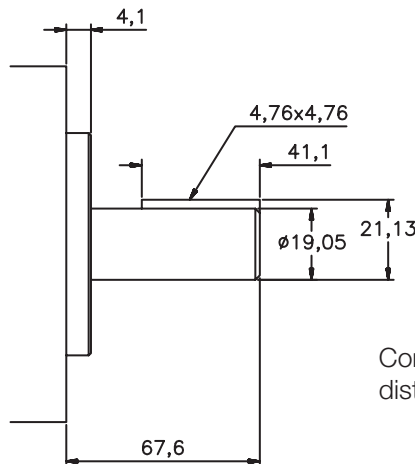

**N°1 Shaft**

Contact **TDZ** or your nearest distributor for other shaft types

**SINGLE VANE PUMP TYPE VC-20**



**FLOW AND INPUT POWER DIAGRAMS**

----- Max. pressure (180 bar)      \_\_\_\_\_ Min. Pressure (7 bar)

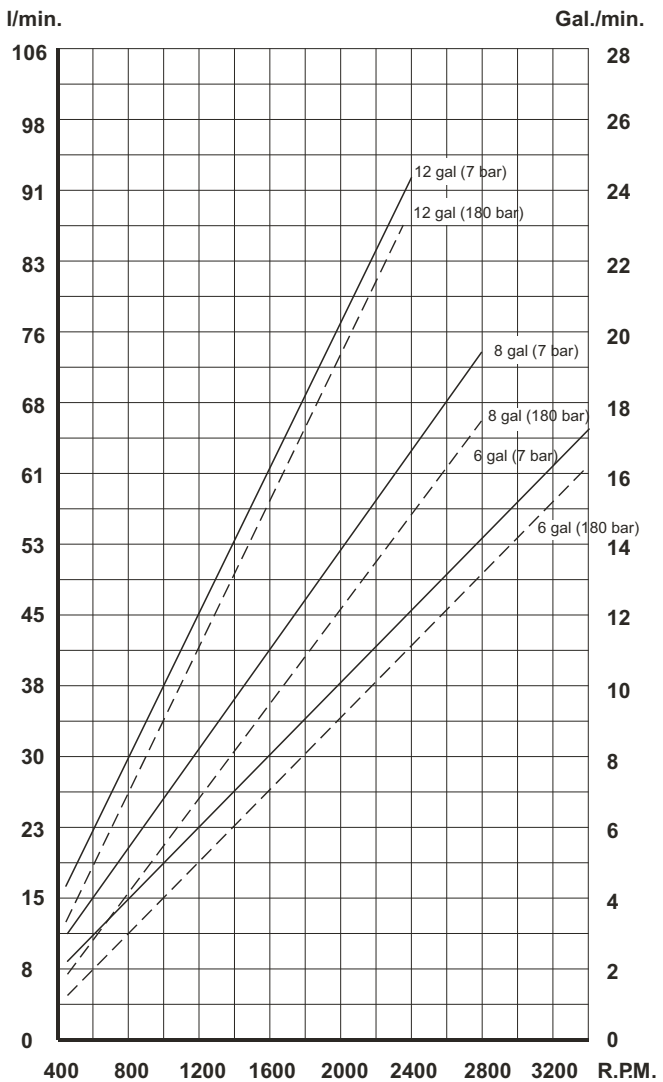
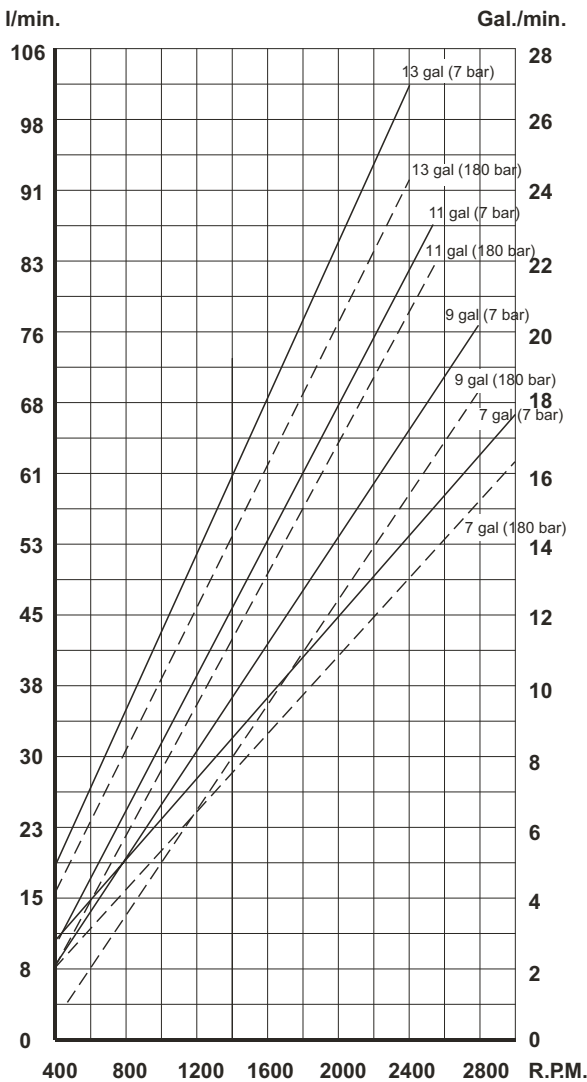
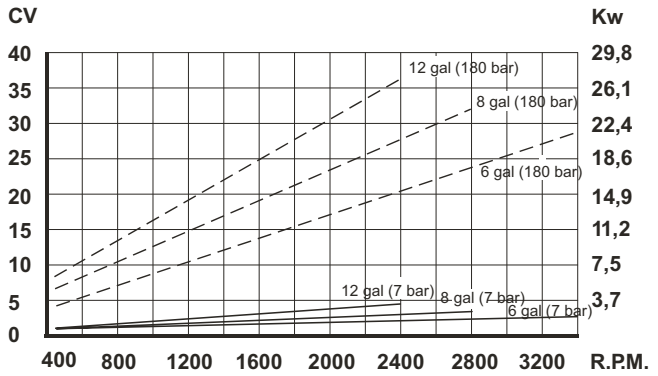
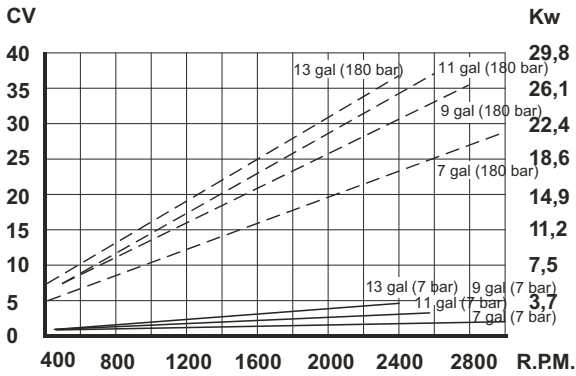

**SINGLE VANE PUMP TYPE VK-20 Y VQ-20**

FLOW								SPEED (rpm)		PRES (BAR)		CONNECTION		WEIGHT (Kgs.)
Lts.at 1000 rpm	8	18	27	29	36	39	46	Min.	Max.	Contin.	Intermit.	Inlet	Outlet	
Gal.at 1200 rpm	2	5	8	9	11	12	14	600	2500	175	210	Ø 1 1/2"	Ø 3/4"	12

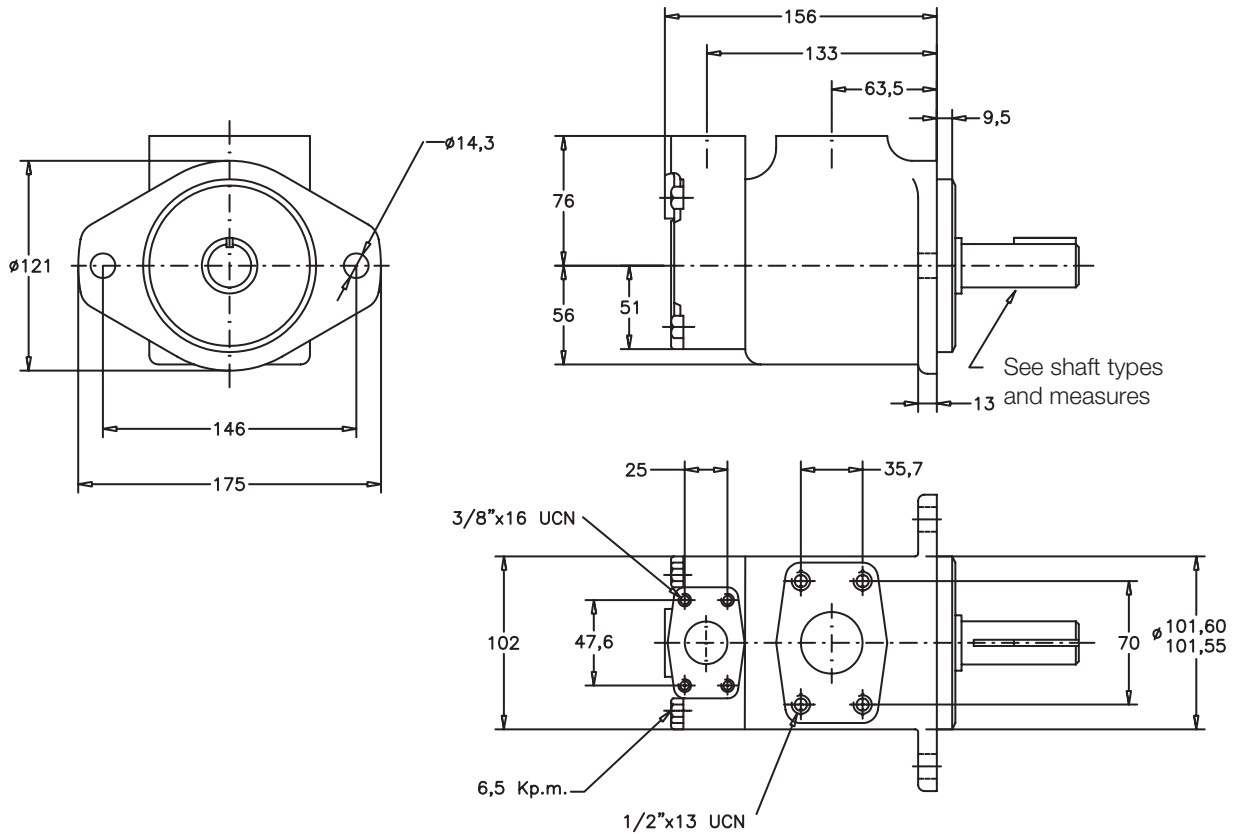

**N°1 Shaft**

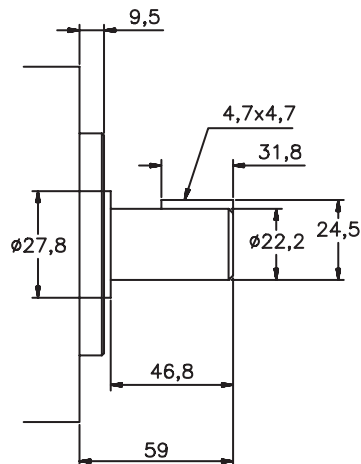

**N°151 Shaft**

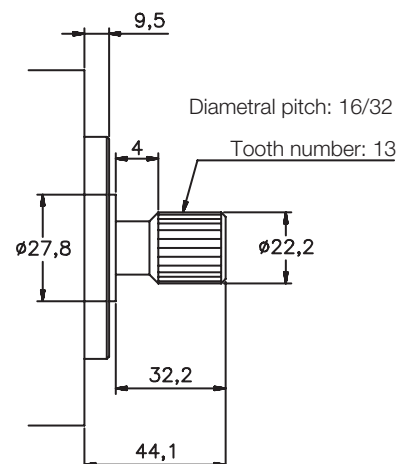

**SINGLE VANE PUMP TYPE VK-20 Y VQ-20**



**FLOW AND INPUT POWER DIAGRAMS**

----- Max. pressure (210 bar)      \_\_\_\_\_ Min. Pressure (7 bar)

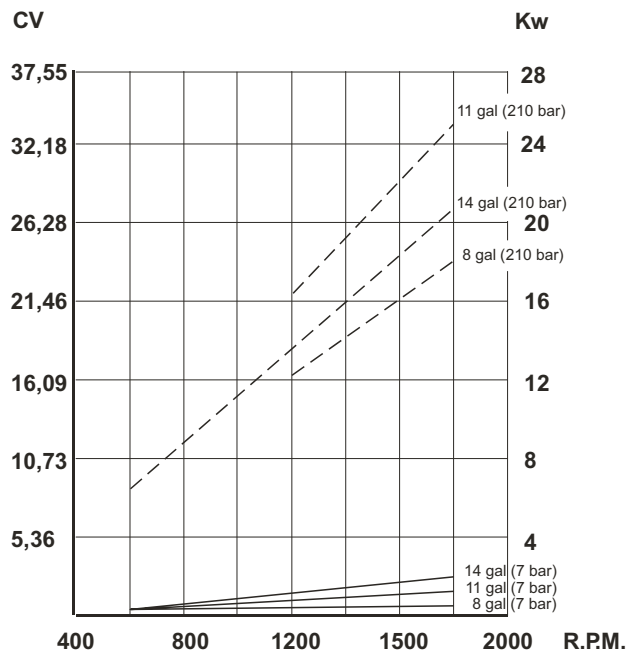
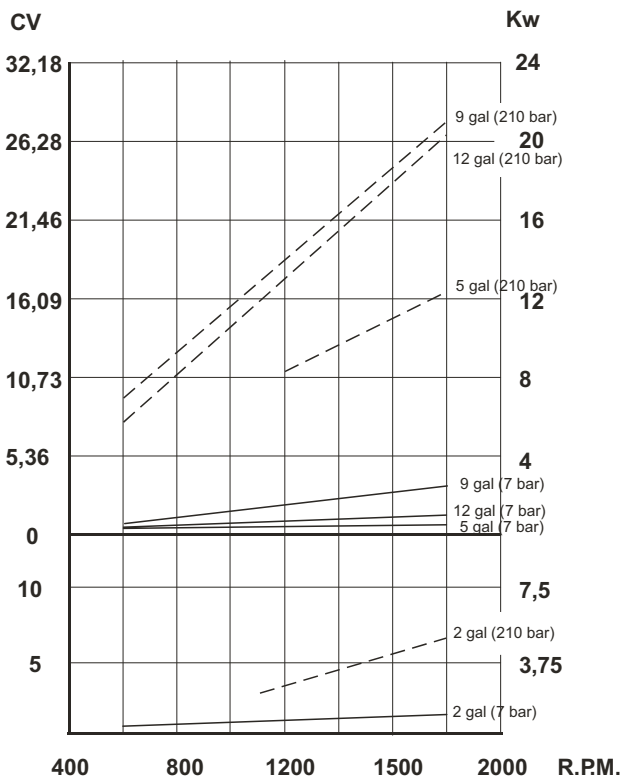
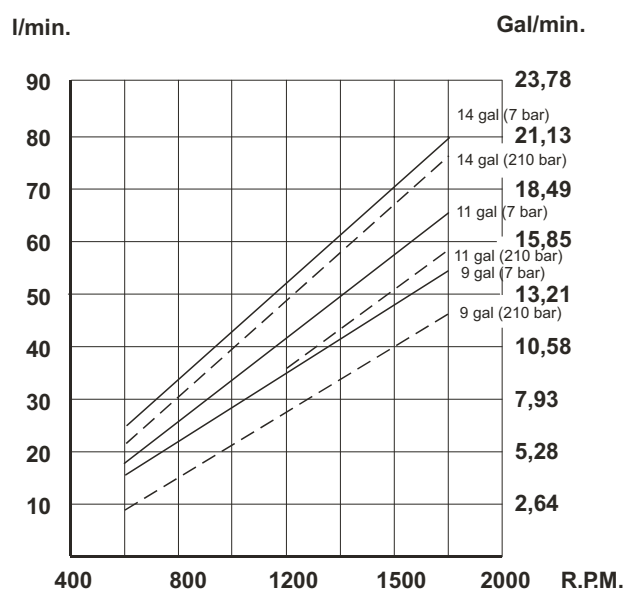
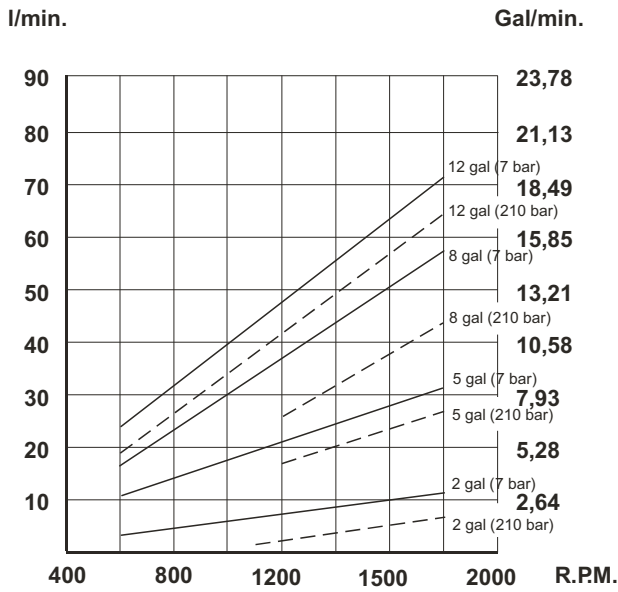

**SINGLE VANE PUMP TYPE VS-25 & VQ-25**

FLOW								SPEED (rpm)		PRES (BAR)		CONNECTION		WEIGHT (Kgs.)	
Lts.at 1000 rpm	26	40	45	55	60	67	80*	88*	Min.	Max.	Contin.	Intermit	Inlet		Outlet
Gal.at 1200 rpm	8	12	14	17	19	21	24*	27*	600	2500*	175	210*	Ø1 1/2	Ø1	15

\*See page 27.

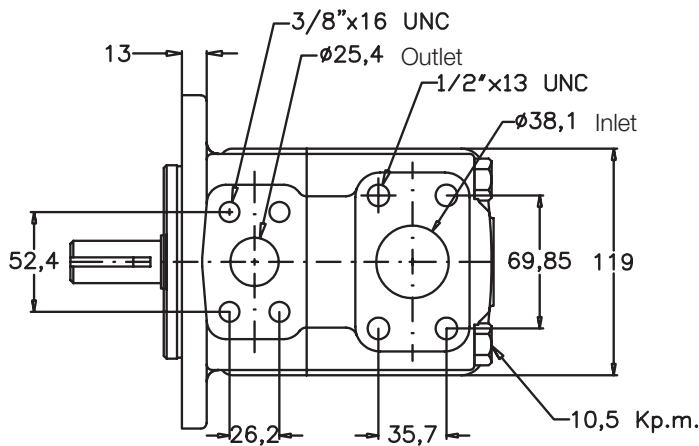
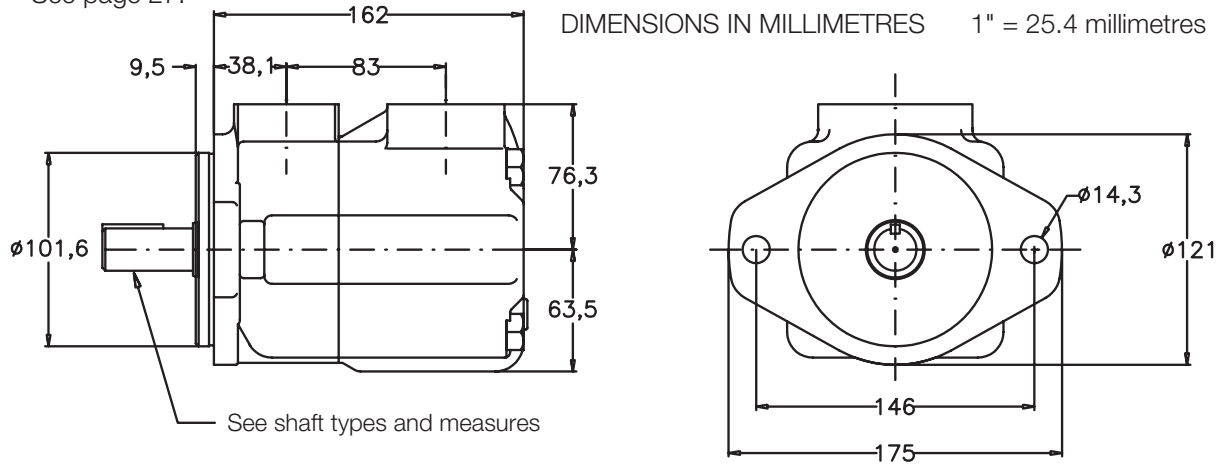

**N°1 Shaft**

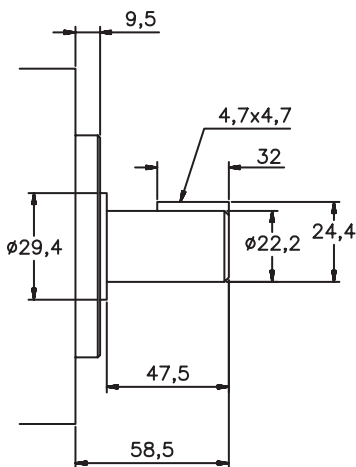

**N°11 Shaft**

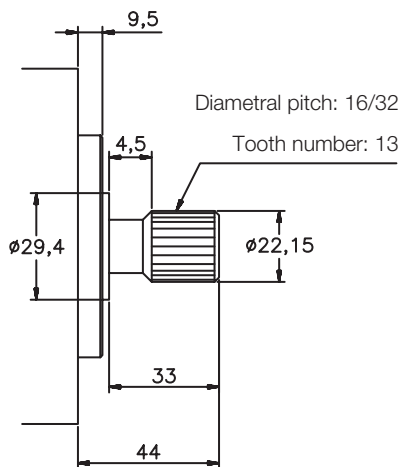

**N°86 Shaft**

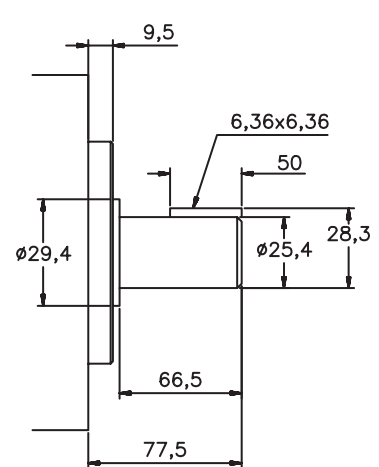

Enquire about other types of shafts



**SINGLE VANE PUMP TYPE VS-25 & VQ-25**



**FLOW AND INPUT POWER DIAGRAMS**

**SINGLE VANE PUMPS**

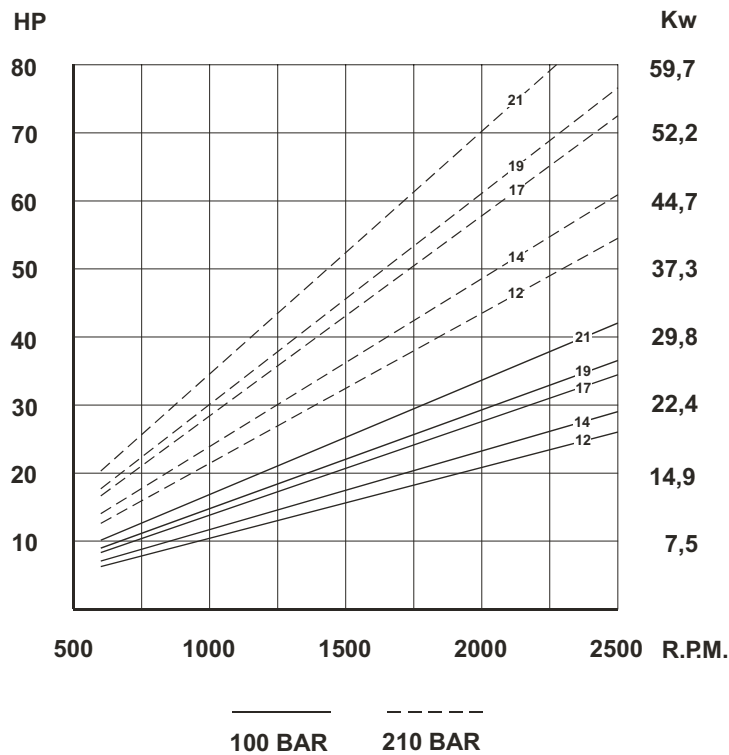
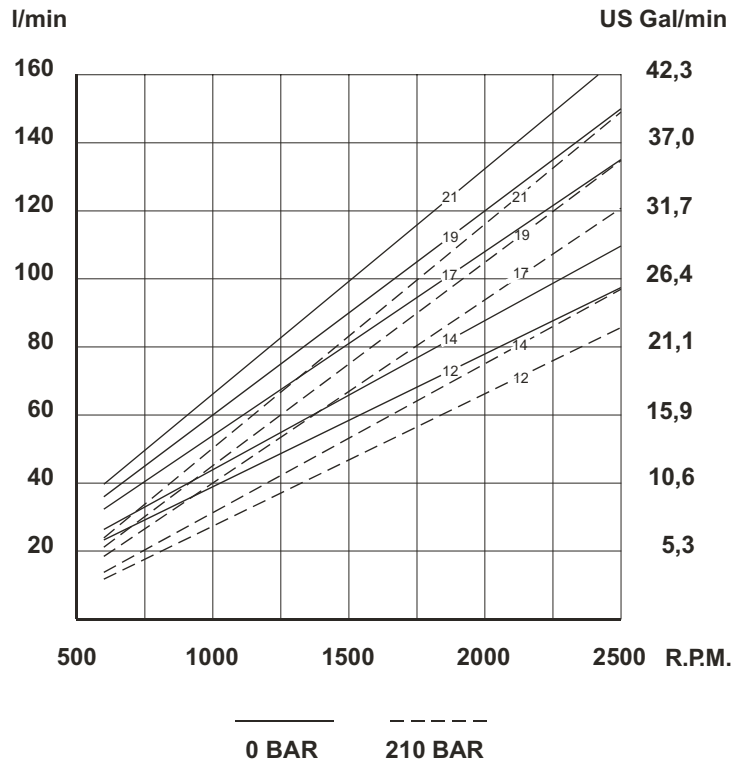

**SINGLE VANE PUMP TYPE VS-35 & VQ-35**

FLOW							SPEED (rpm)		PRES (BAR)		CONNECTION		WEIGHT
Lts.at 1000 rpm	66	81	97	112	121	142*	Min.	Max.	Contin.	Intermit.	Inlet	Outlet	(Kgs.)
Gal.at 1200 rpm	21	25	30	35	38	45*	600	2400*	175	210*	Ø2"	Ø1"1/4	23

\*See page 27.

\* For further details see general chart

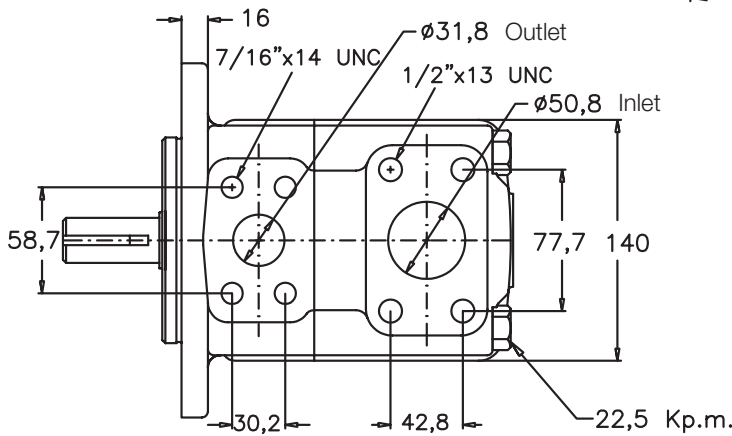
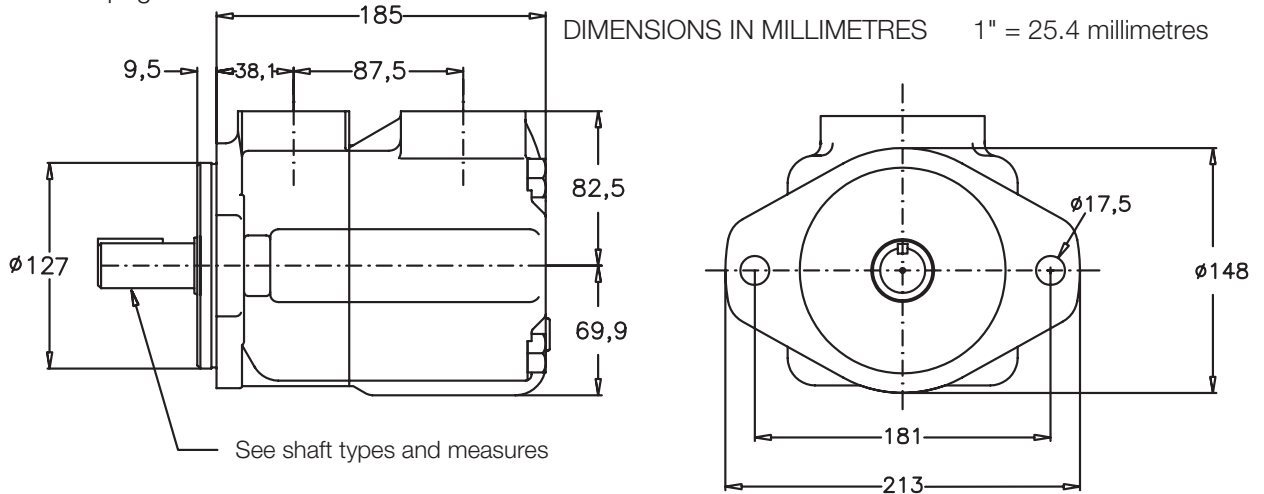

**N°1 Shaft**

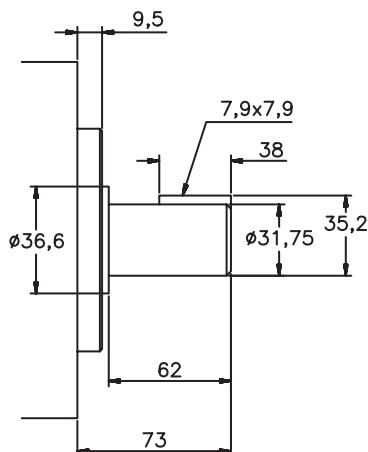

**N°11 Shaft**

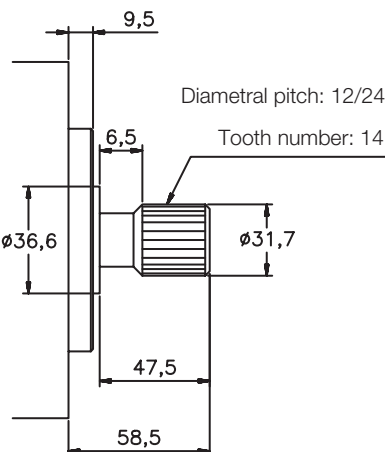

**N°86 Shaft**

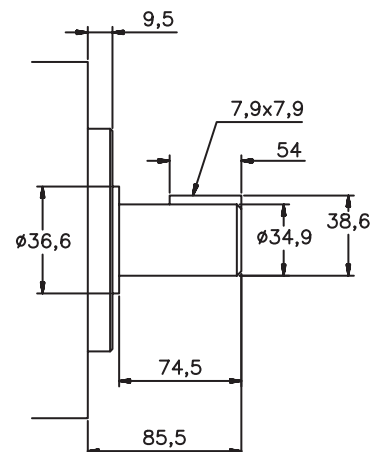

Enquire about other types of shafts

**SINGLE VANE PUMP TYPE VS-35 & VQ-35**



**FLOW AND INPUT POWER DIAGRAMS**

**SINGLE VANE PUMPS**

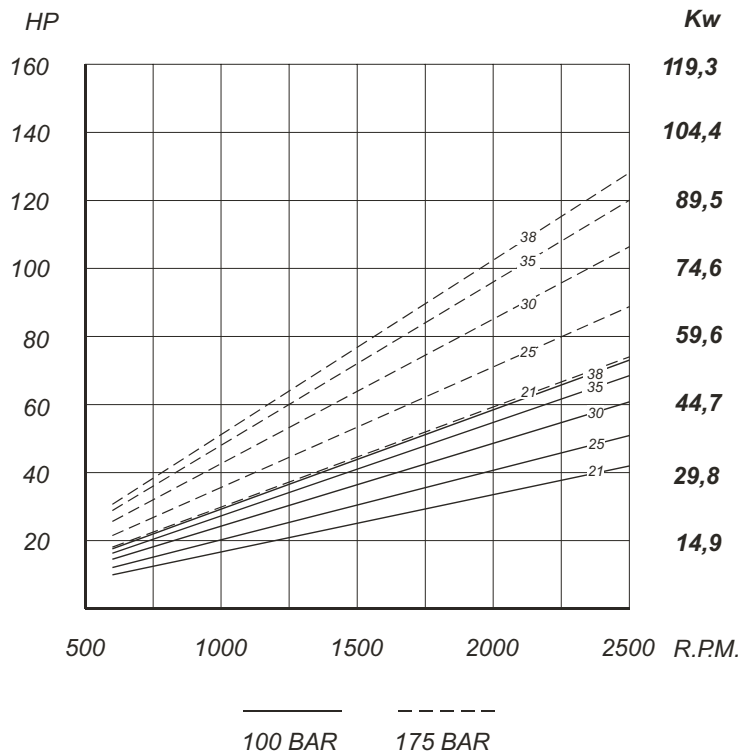
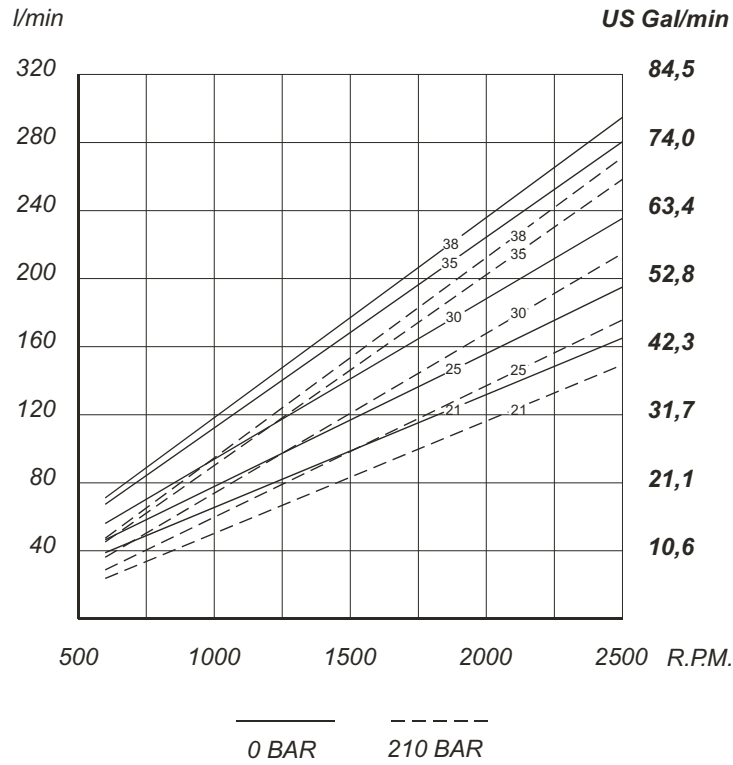

**SINGLE VANE PUMP TYPE VS-45 & VQ-45**

FLOW								SPEED (rpm)		PRES (BAR)		CONNECTION		WEIGHT	
Lts. a 1000 rpm		138	148	162	180	193	214	240	Min.	Máx.	Contin.	Intermit.	Inlet	Outlet	(Kgs.)
Gal. a 1200 rpm		42	47	50	57	60	67	75	600	2200*	155	175	Ø3"	Ø1"1/2	35,5

\* For further details see general chart

DIMENSIONS IN MILLIMETRES 1" = 25.4 millimetres

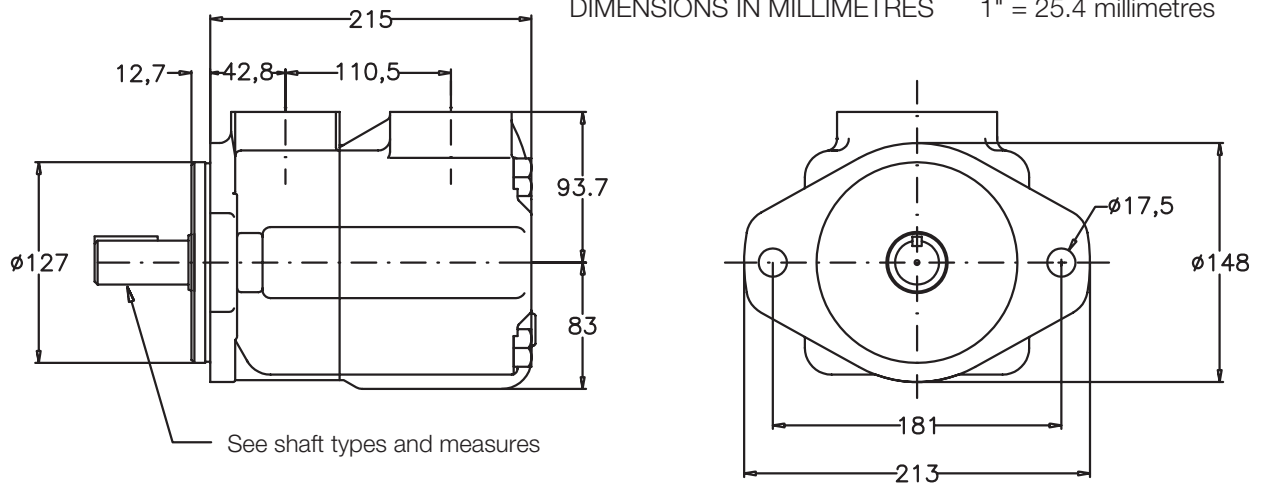

See shaft types and measures

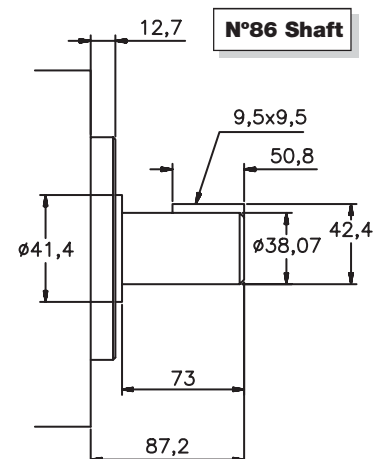
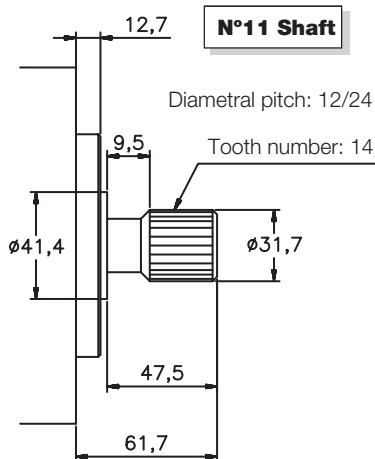
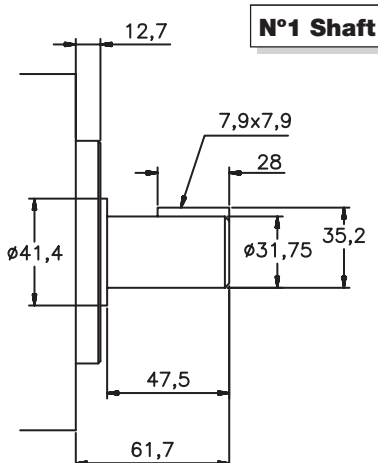
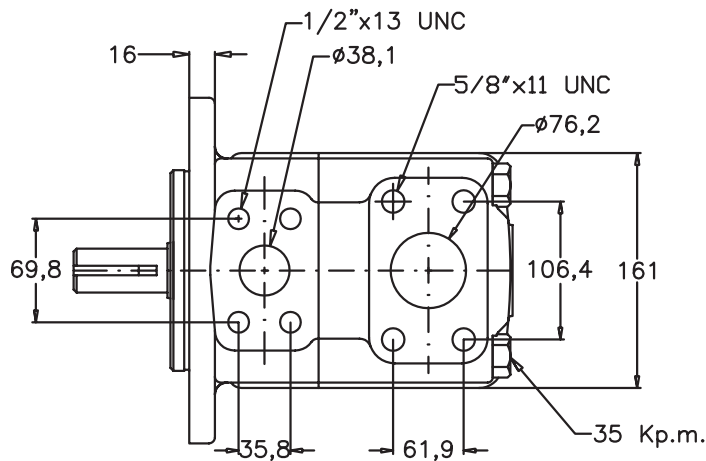

Enquire about other types of shafts

**SINGLE VANE PUMP TYPE VS-45 & VQ-45**



**FLOW AND INPUT POWER DIAGRAMS**

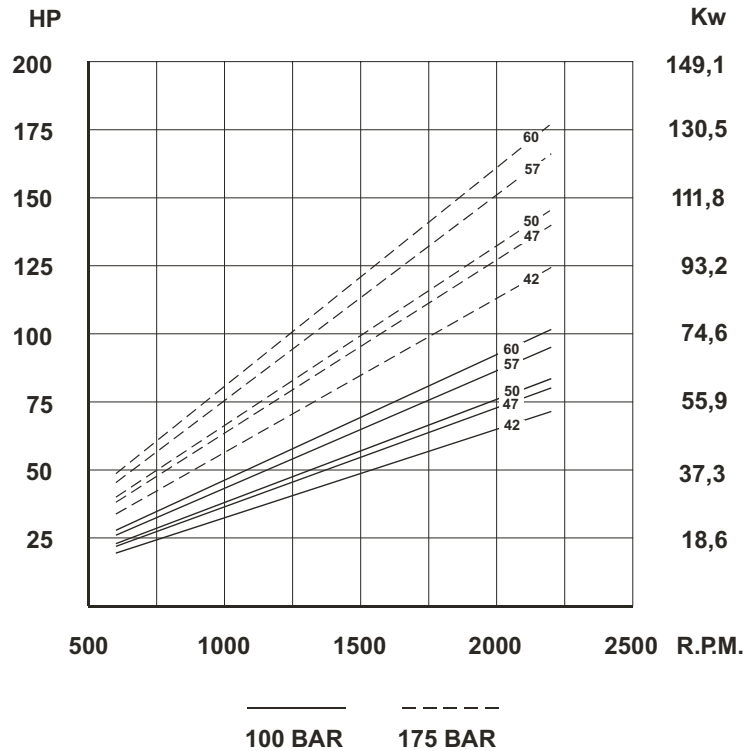
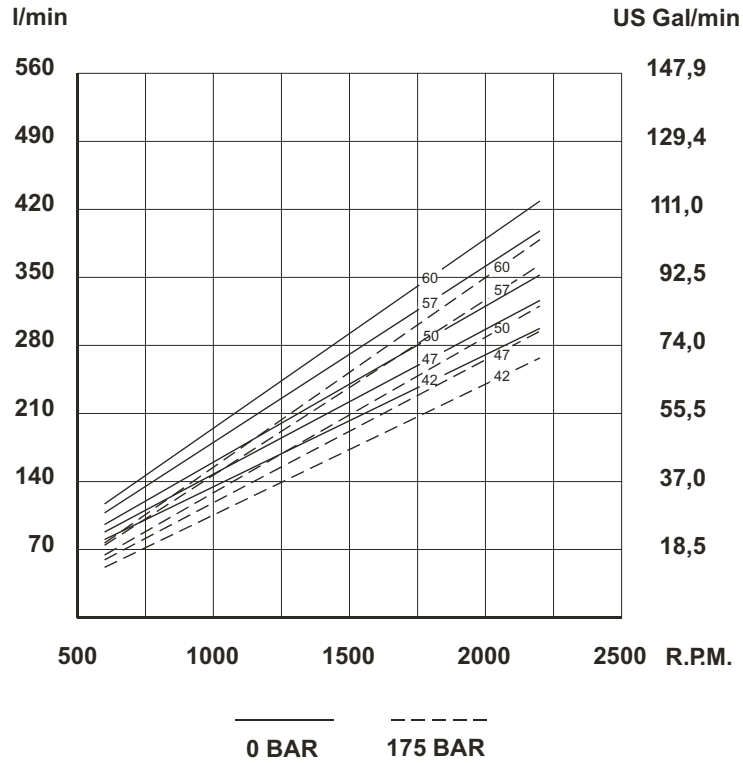

## DT-6 SINGLE VANE PUMPS ORDERING CODE

**DT6 - C - \* - B - 17 - 1 - R - 00 - B - 1 - M**

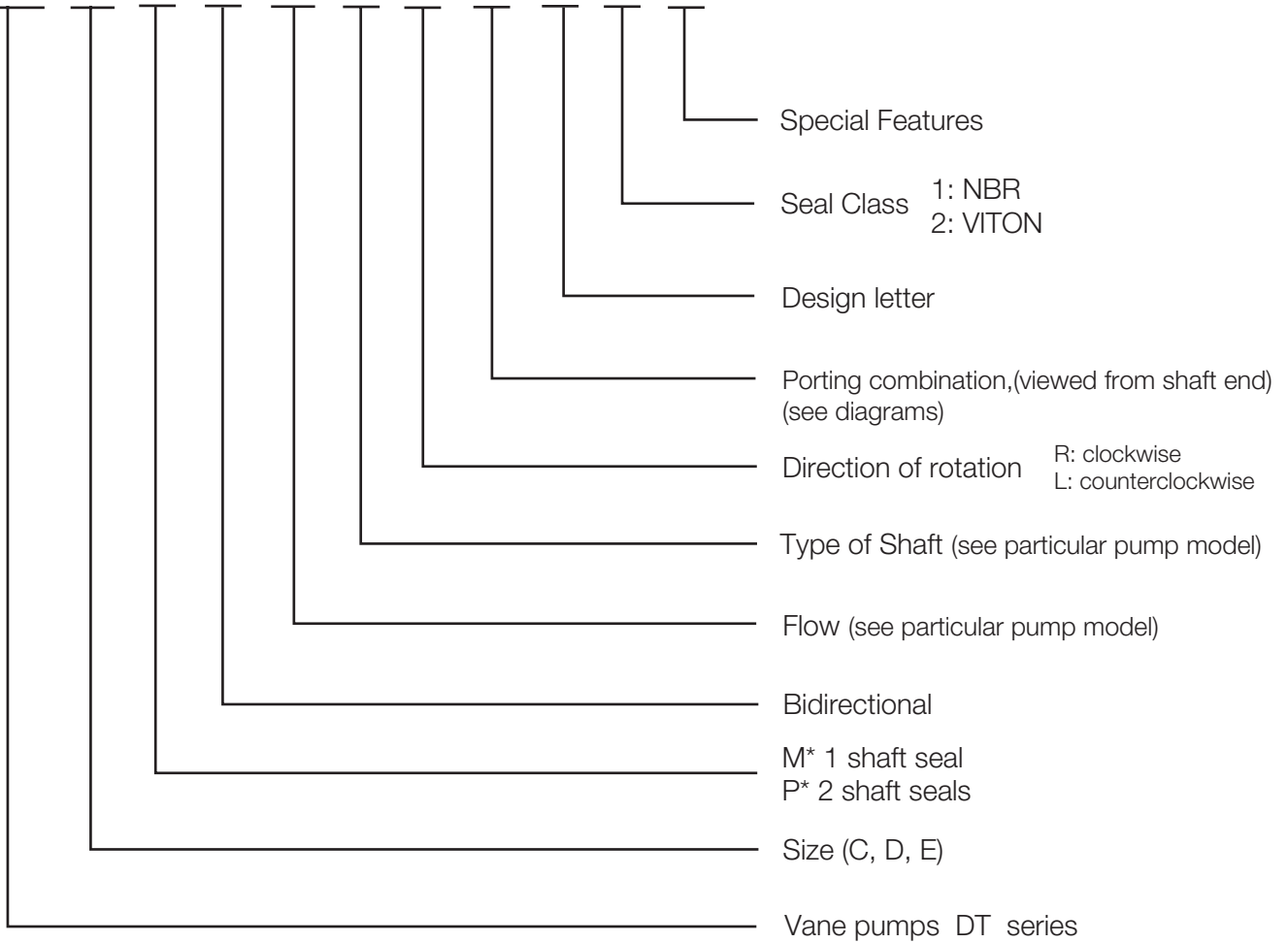

**SINGLE PUMPS**

Pump Model	Cartridge model	Theoretical displacement Cm <sup>3</sup> /rev	Maximum Pressure	Max. speed rpm	Min. speed rpm	Weight Kgs	Front flange Standard SAE j744c ISO 3019-1	SAE 4 holes flange	
								Suction	Pressure
<b>DT6C</b>	003	10.8	275	2800	400	15	SAE B	1 ½"	1"
	005	17.2							
	006	21.3							
	008	26.4							
	010	34.1							
	012	37.1							
	014	46.0							
	017	58.3							
	020	63.8							
	022	70.3							
	025	79.3							
	028	88.8	210	2500					
	031	100							
DT6CP Pump model only mount B14 to B31 cartridges									
<b>DT6D</b>	014	47.6	240	2500	400	24	SAE C	2"	1 1/4"
	020	66.0							
	024	79.5							
	028	89.7							
	031	98.3							
	035	111.0							
	038	120.3							
	042	136.0							
	045	145.7							
	050	158.0							
	061	190.5	210	2200					
		120	1800						
<b>DT6E</b>	042	132.3	240	2200	400	44	SAE C	3"	1 ½"
	045	142.4							
	050	158.5							
	052	164.8							
	062	196.7							
	066	213.3							
	072	227.1							
	085	269.8	90	2000					

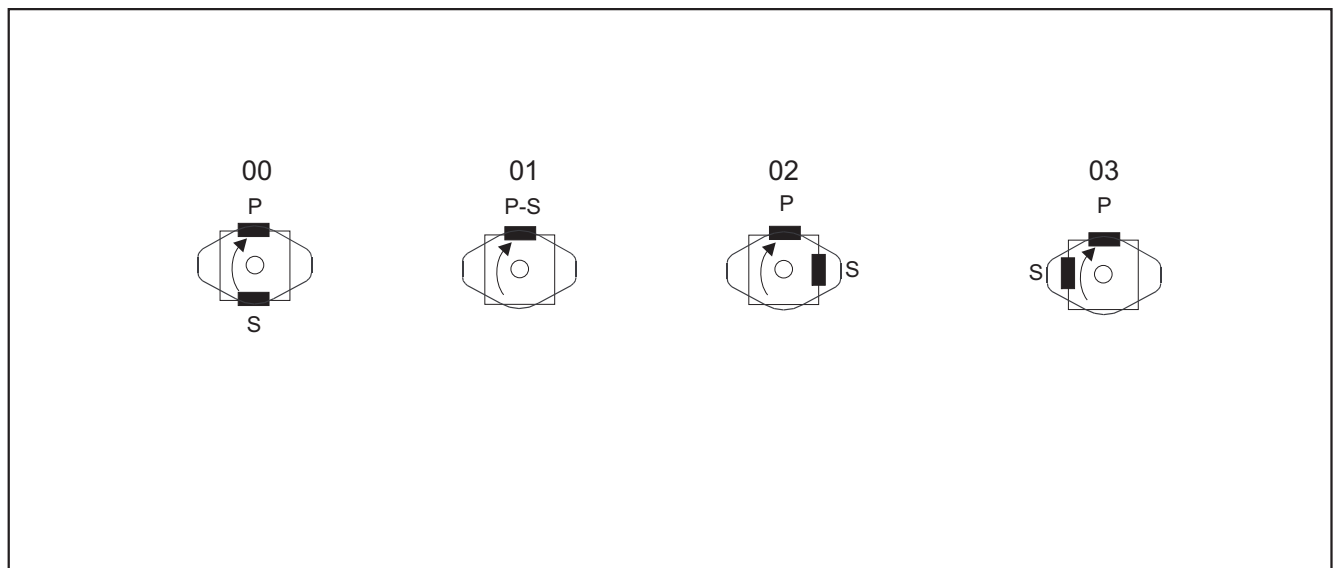

FLOW											SPEED (rpm)		PRESSURE (bar)		WEIGHT		
Lts/min.at 1000 rpm											Mín.	Máx.	Intermit.	Contin.	(Kgs.)		
11	17	21	26	34	37	46	58	64	70	79	89	100	400	2800*	275	240*	15
Gal/min.at 1200 rpm																	
3	5	6	8	10	12	14	17	20	22	25	28	31					

\* See page 41 for further information about speed & pressure.

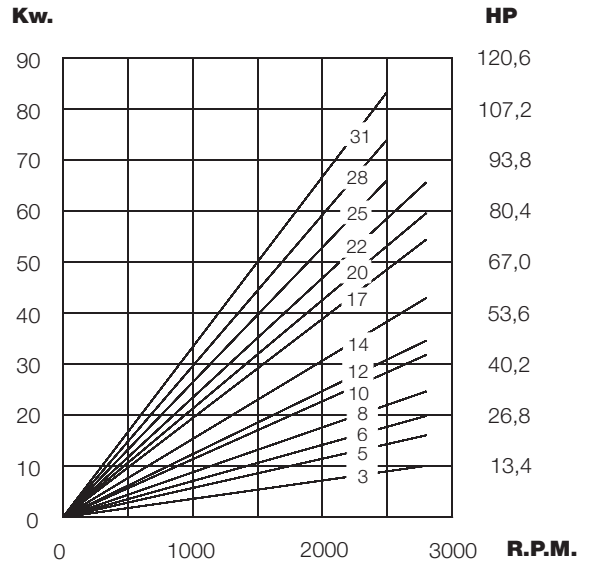
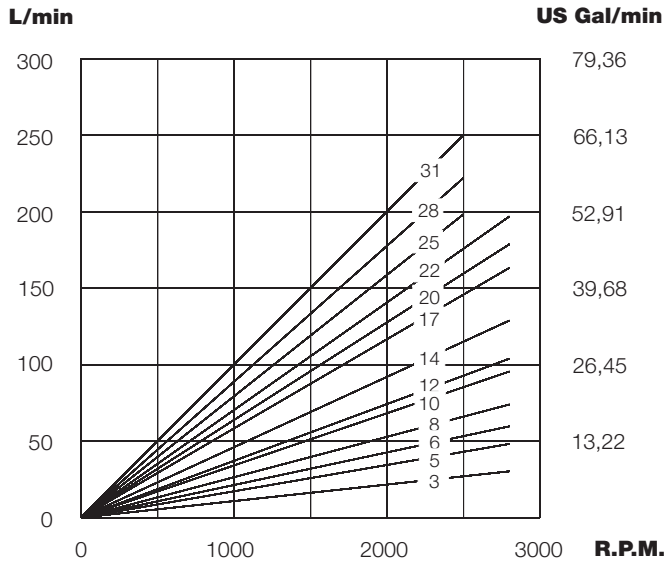

### Theoretical Flow (0 Bar)

To calculate the real flow at a given operating pressure, subtract the internal leakage value for this pressure (see diagram below) from the theoretical flow. (See diagram above).

### Theoretical Input Power at 200 Bar

To calculate the theoretical input power at other pressures and speeds, use the formula:

$$P(Kw) = \frac{Q(L/min.) \times P(Bar)}{600}$$

Where Q is the theoretical flow (upper left diagram) and P the operating pressure.

To calculate the real input power, add to the theoretical power the hydromechanical power losses. (see diagram below).

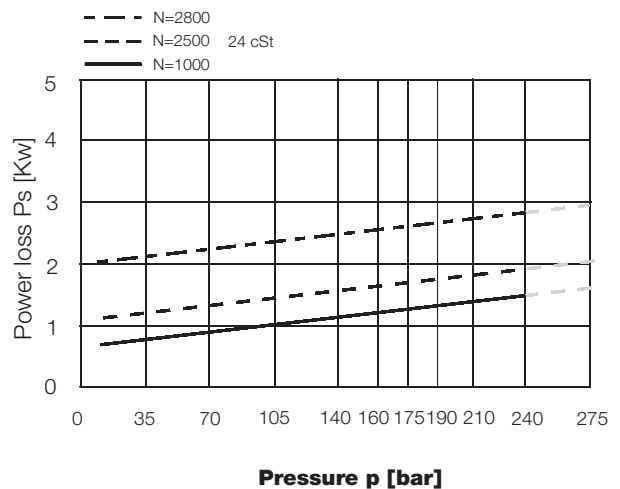
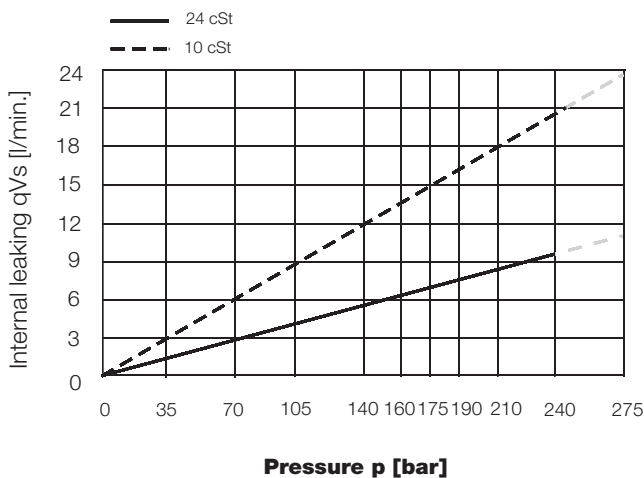

Do not operate pump more than 5 seconds at any speed or viscosity if internal leakage is more than 50 % of theoretical flow



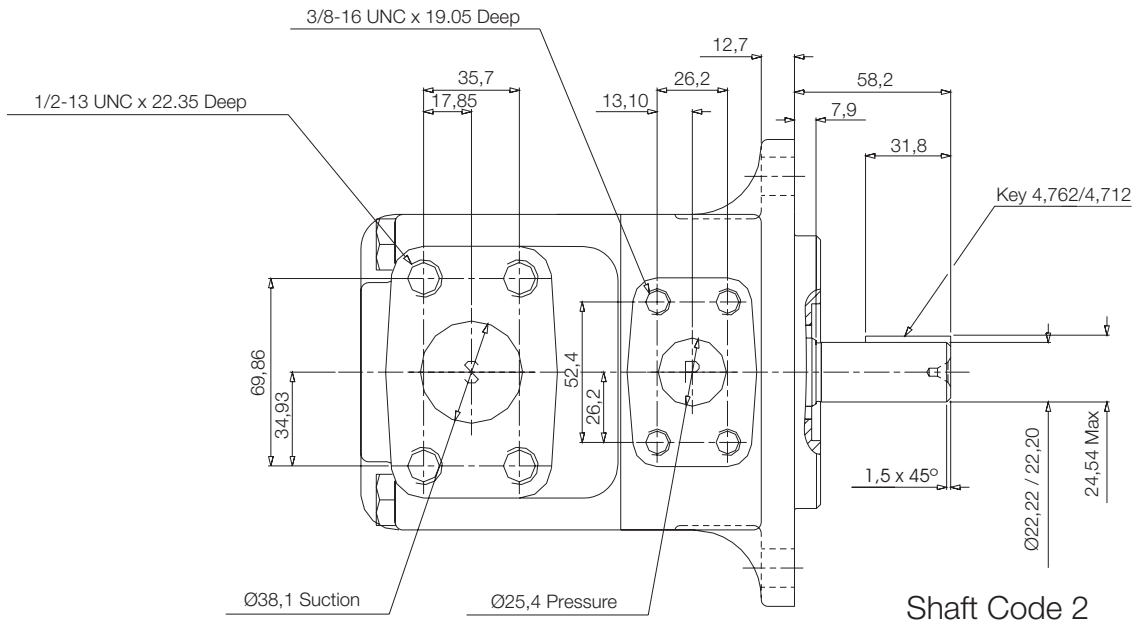
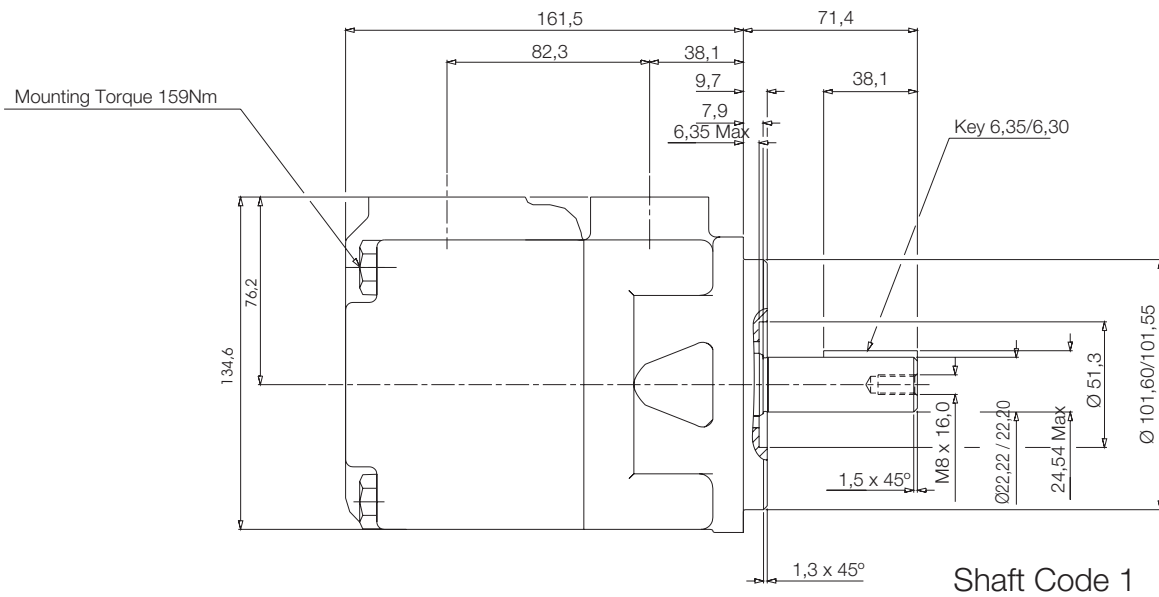
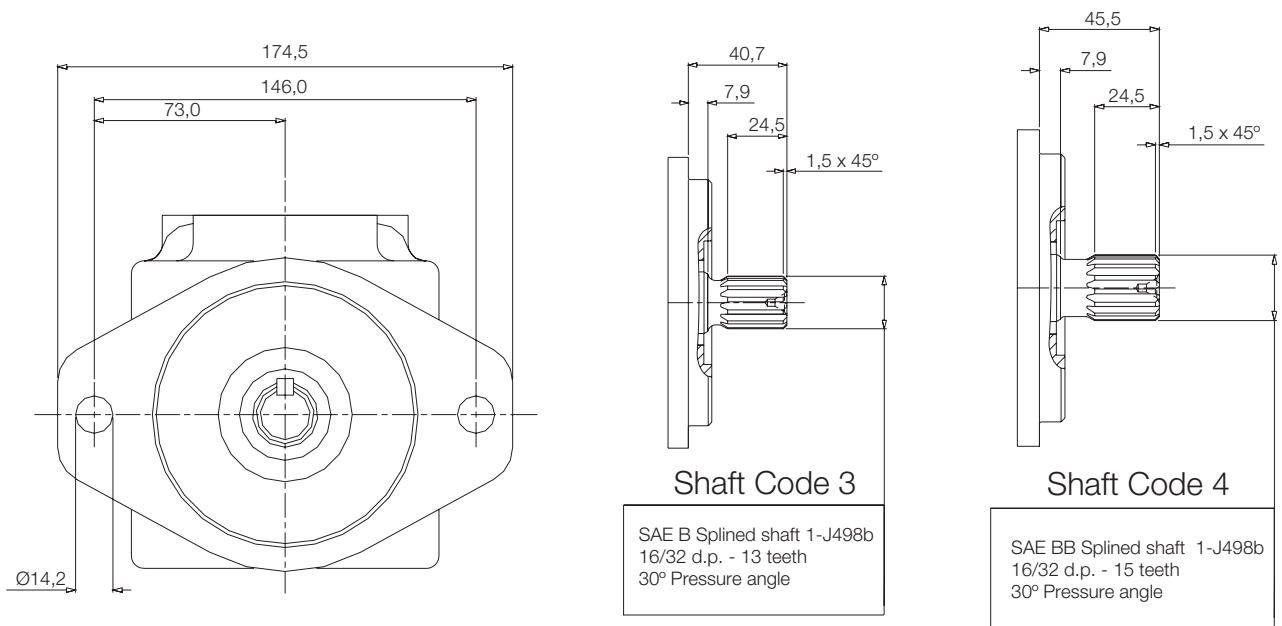

FLOW											SPEED (rpm)		PRESSURE (bar)		WEIGHT
Lts/min.at 1000 rpm											Mín.	Máx.	Intermit.	Contín.	(Kgs.)
48	66	80	90	98	111	120	136	146	158	191	400	2500*	240	210	24
Gal/min.at 1200 rpm															
14	20	24	28	31	35	38	42	45	50	61					

\* See page 41 for further information about speed & pressure.

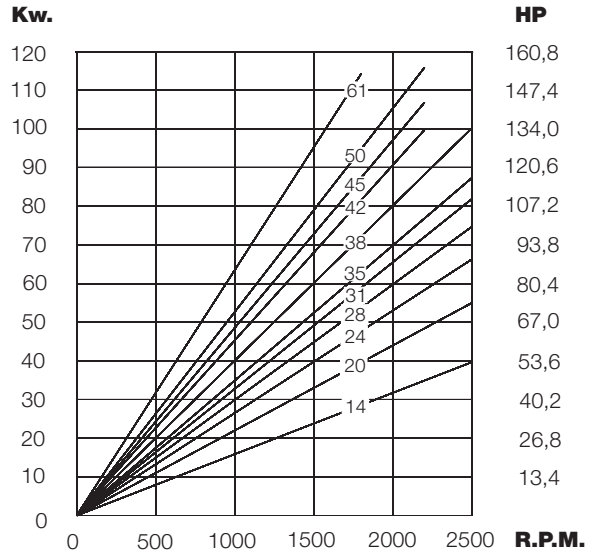
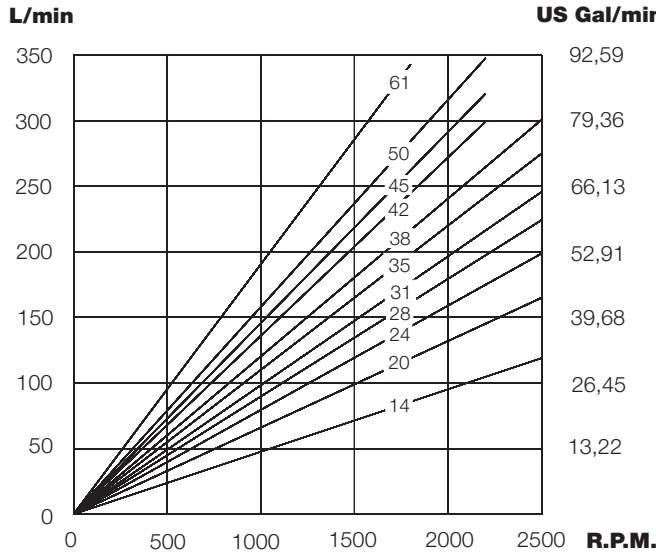

### Theoretical Flow (0 Bar)

To calculate the real flow at a given operating pressure, subtract the internal leakage value for this pressure (see diagram below) from the theoretical flow. (See diagram above).

### Theoretical Input Power at 200 Bar

To calculate the theoretical input power at other pressures and speeds, use the formula:

$$P(Kw) = \frac{Q(L/min.) \times P(Bar)}{600}$$

Where Q is the theoretical flow (upper left diagram) and P the operating pressure.

To calculate the real input power, add to the theoretical power the hydromechanical power losses. (see diagram below).

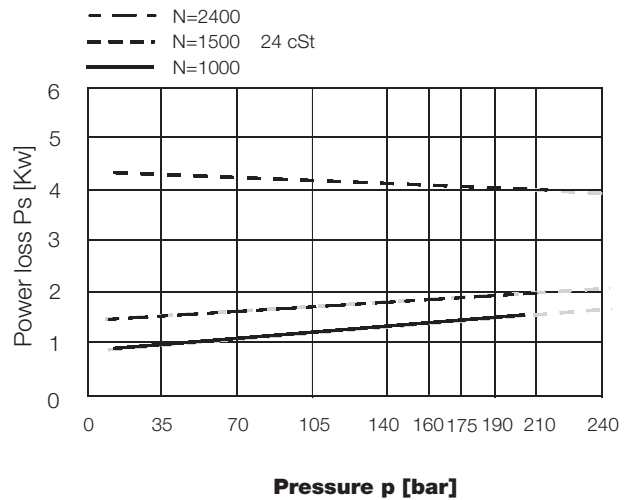
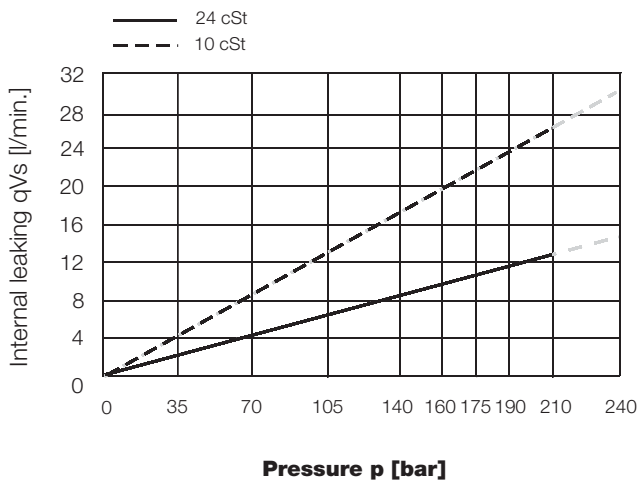

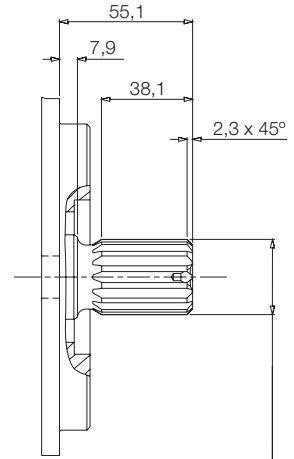
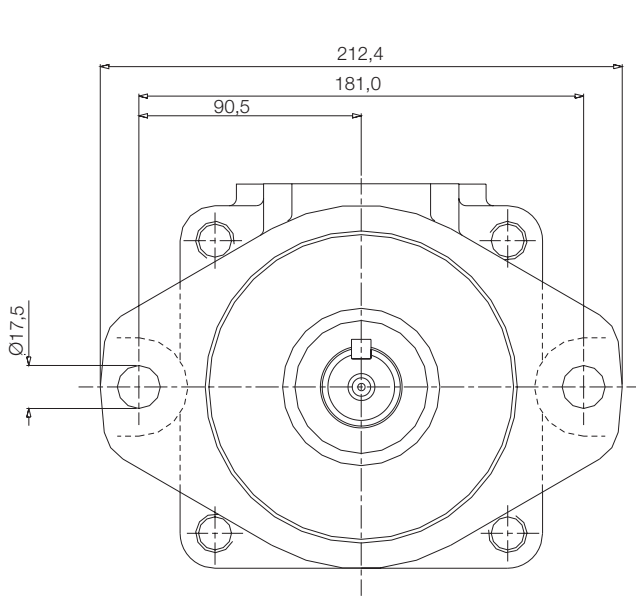

**Shaft Code 3**

SAE C Splined shaft 1-J498b  
12/24 d.p. - 14 Teeth  
30° Pressure angle

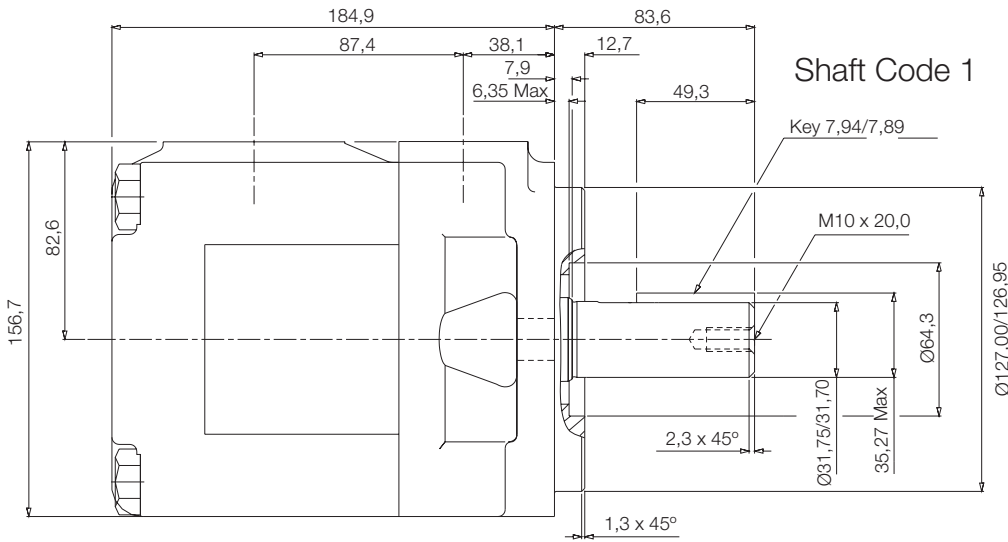

**Shaft Code 1**

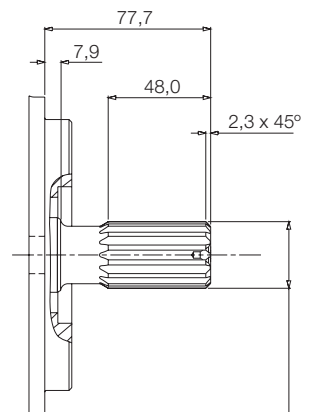

**Shaft Code 4**

No SAE Splined shaft 1-J498b  
12/24 d.p. - 14 Teeth  
30° Pressure angle

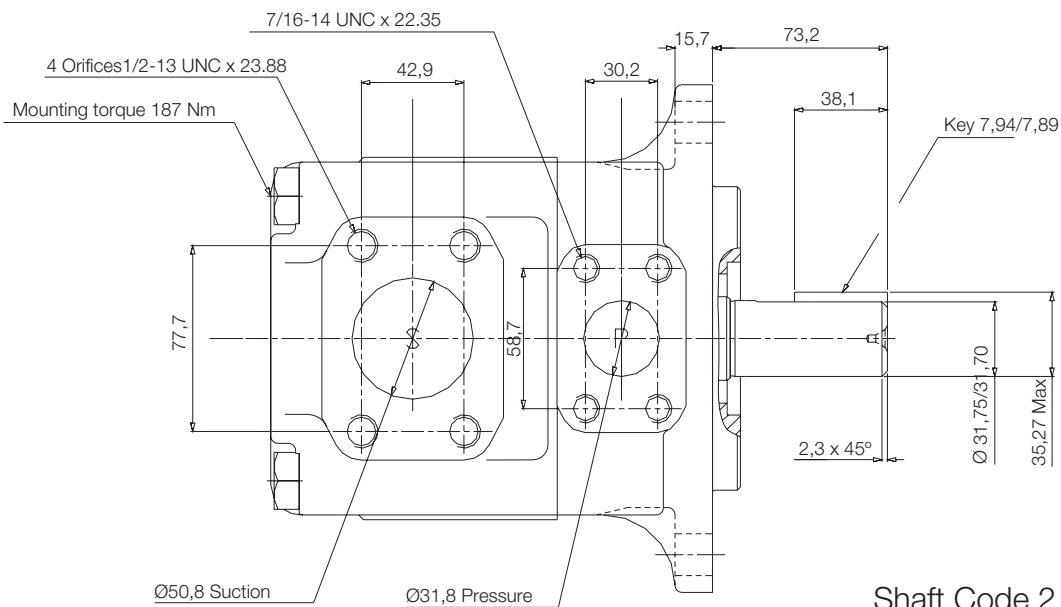

**Shaft Code 2**

FLOW									SPEED (rpm)		PRESSURE (bar)		WEIGHT
Lts/min.at 1000 rpm	132	142	156	165	197	213	227	270	Mín.	Máx.	Intermit.	Contin.	(Kgs.)
Gal/min.at 1200 rpm	42	45	50	52	62	66	72	85	400	2200*	240	210	44

\* See page 41 for further information about speed & pressure.

L/min

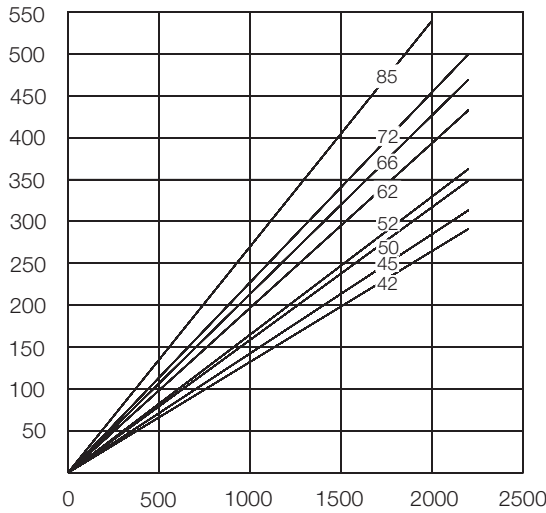

US Gal/min



Kw.



HP

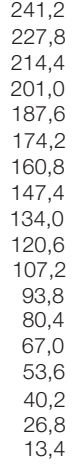

### Theoretical Flow (0 Bar)

To calculate the real flow at a given operating pressure, subtract the internal leakage value for this pressure (see diagram below) from the theoretical flow. (See diagram above).

### Theoretical Input Power at 200 Bar

To calculate the theoretical input power at other pressures and speeds, use the formula:

$$P(Kw) = \frac{Q(L/min.) \times P(Bar)}{600}$$

Where Q is the theoretical flow (upper left diagram) and P the operating pressure.

To calculate the real input power, add to the theoretical power the hydromechanical power losses. (see diagram below).

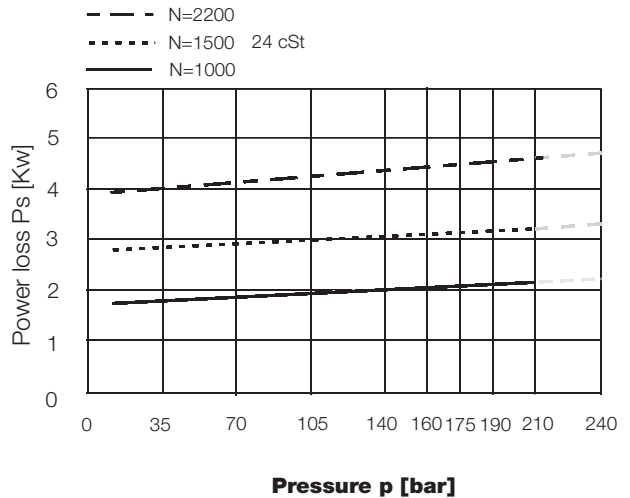
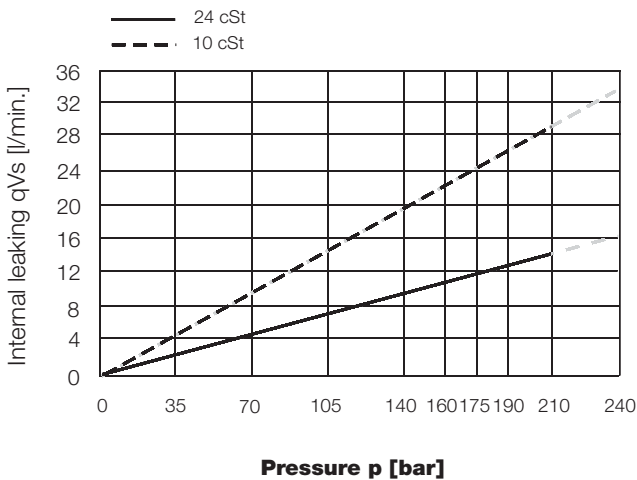

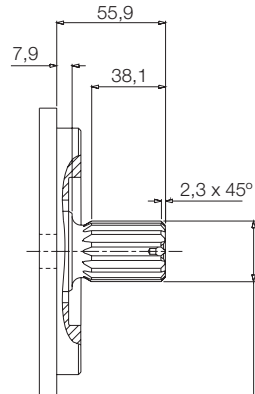
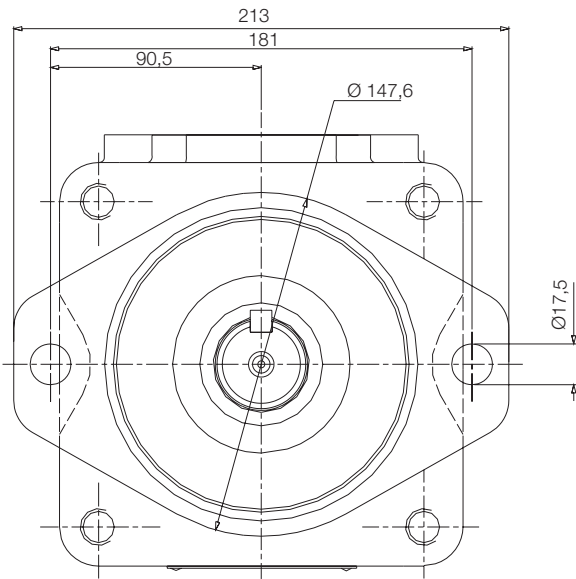

**Shaft Code 3**

SAE C Splined shaft 1-J498b  
12/24 d.p. - 14 Teeth  
30° Pressure angle

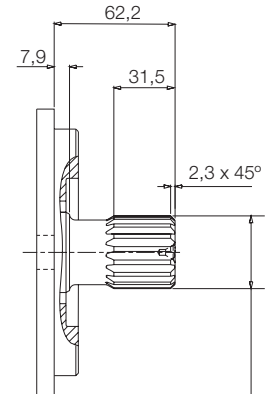

**Shaft Code 4**

SAE C-C Splined shaft  
1-J498b 12/24 d.p. - 17 Teeth  
30° Pressure angle

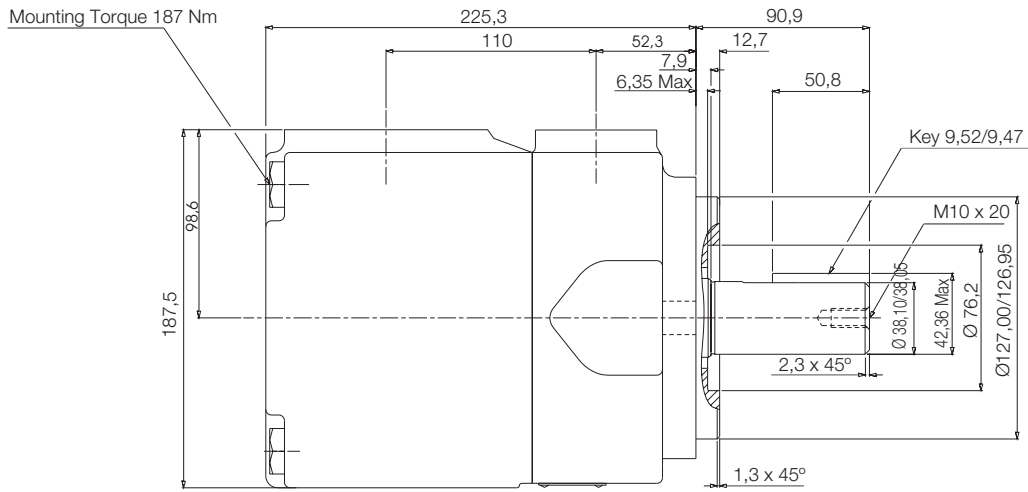

**Shaft Code 1**  
SAE C-C

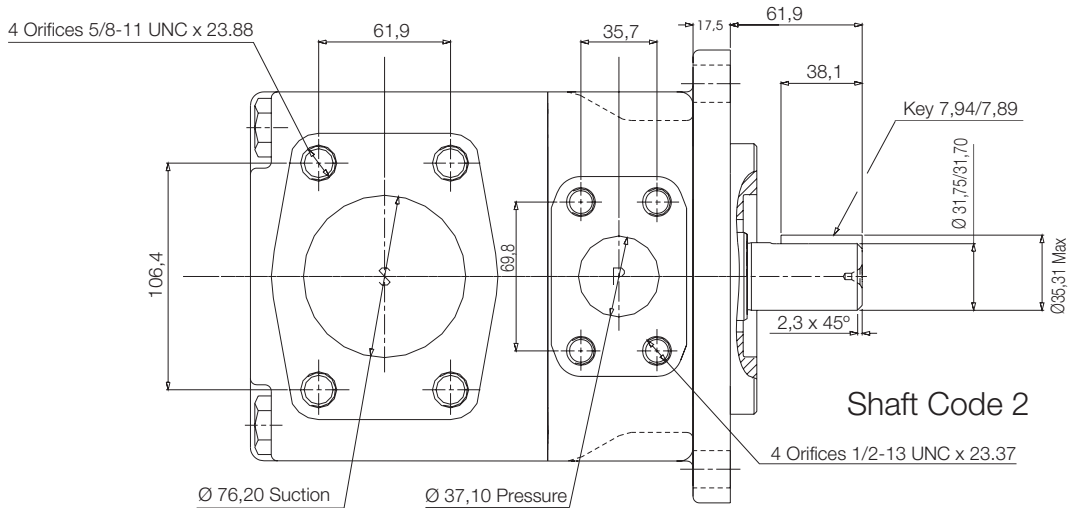

**Shaft Code 2**

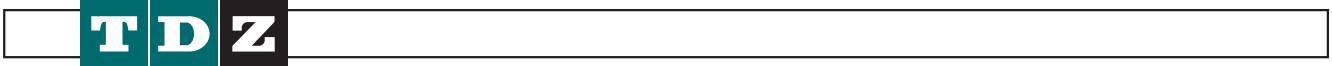

hydraulics

# THRU DRIVE SINGLE VANE PUMPS

V\*\*T thru drive single vane pumps

See single V\* pumps for displacement & power diagrams (Pages 35, 37.39)

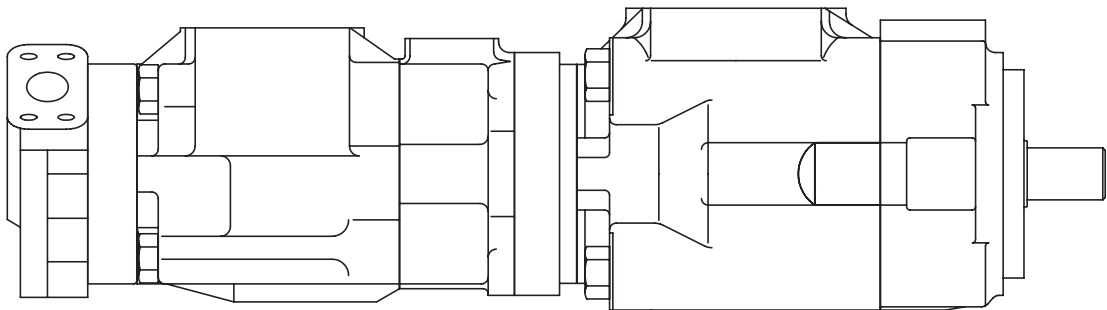

V\*7TC thru drive pump with V\*64 double pump

**V\* THRU DRIVE SINGLE VANE PUMPS ORDERING CODE**

F3	VS	7T	C	60	D	86	A	A
1	2	3	4	5	6	7	8	9

**1 - "F3"** means special seals for fire-resistant fluids. Omit if not required

**2 - Pump Type:**

**VS = 12 vane pump**, industrial use (very quiet), UNC threads

**VQ = 10 vanes and bronze plates pump**, mobile use, UNC threads

**3 - Pump model:** 4T, 6T and 7T.

**4 - Rear pump mounting:** With SAE mounting flange, 2-bolts.

**A:** SAE-A mounting flange

**B:** SAE-B mounting flange

**C:** SAE-C mounting flange

**5 - Flow:** In US Gallons per minute at 1200 rpm and 7 bar.

**6 - D =** Right-hand direction of rotation (Clockwise)

**Y =** Left-hand direction of rotation.

(To check the direction of rotation view from the shaft end).

**7 - Shaft type:**

1: Parallel keyed

11: Splined

86: Heavy duty parallel keyed

**8 - Outlet position, (viewed from shaft):**

A: In line with inlet

B: 90° on the right from inlet (Clockwise from inlet)

C: 180° from inlet

D: 90° on the left from inlet (Counterclockwise from inlet)

**9- Rear flange positions, (viewed from the flange):**

SAE A flanges:

A: 45° on the right (Clockwise)

B: 45° on the left (Counterclockwise)

SAE-B and SAE-C flanges:

A: In line with in-front flange

B: 90° rotated



# THRU DRIVE SINGLE VANE PUMPS CHARACTERISTICS

**THRU DRIVE SINGLE VANE PUMPS**

TYPE	FLOW			SPEED (rpm)		PRESSURE (Bar)		Nominal Power (2)	CONNECTION		WEIGHT (Kgs.)
	Lts.at 1000 rpm	Gal. At 1200 rpm	Reduction (1)	Mín.	Máx.	Contin.	Intermit.		Inlet	Outlet	
<b>VS4T VQ4T</b>	26	8	4,5	600	2500 1800 (VS)	175	210	6,9 10,4 11,6 13,8 14,6 16,8 20,3 23,8	Ø64	Ø25,4	19,5
	40	12	5,7								
	45	14	5,7								
	55	17	5,8								
	60	19	5,8								
	67	21	6								
	80	24	6,2								
88*	27	6,5	1500	125	150						
<b>VS6T VQ6T</b>	66	21	8,6	600	2400 1800 (VS)	175	210	16,8 20,3 24,3 27,4 29,3 33,3	Ø76	Ø31,8	29,5
	81	25	9								
	97	30	10								
	112	35	11,4								
	121	38	11,4								
	142	45	13,1								
<b>VS7T VQ7T</b>	138	42	15	600	2200 1800 (VS)	155	175	32,3 36,3 37,9 43,2 46,1 51,2 57,4	Ø89	Ø38,1	38
	148	47	15,7								
	162	50	14,3								
	180	57	17,9								
	193	60	18,6								
	214	67	22								
	240	75	26								

**(1)** Delivery flow reduction in Ltrs./min. at 100 Bar. 22 cST of oil viscosity at operating temperature. To calculate the approximate delivery flow at a given pressure and speed, use the following formula with flow reduction and theoretical flow values shown in the chart. Flow reduction values are independent of shaft speed.

$$\text{Approx. output flow (Ltrs./min.)} = \text{Theoretical flow} \times \frac{\text{R.P.M}}{1000} - \text{Reduction} \frac{\text{Pressure (bar)}}{100}$$

**(2)** Nominal power in H.P. at 100 Bar and 1000 RPM (to convert into Kw multiply by 0.735). To obtain the real input power at different pressure and revolutions, use the formula as follows:

$$\text{Real input power} = \text{Input power} \times \frac{\text{R.P.M}}{1000} \times \frac{\text{Pressure (bar)}}{100}$$

### REAR PUMP MOUNTING

The mounted pump to the V\*\*T\* should have the shaft shown below:

Model	Mounted pump shaft			
	DP splined	Teeth	Press angle	Flange
V**TA	16/32	9	30°	SAE-A
V**TB	16/32	13	30°	SAE-B
V**TC	12/24	14	30°	SAE-C

### TRANSMISSIBLE MAXIMUM TORQUE

The torque of the V\*\*T plus the torque of the rear pump, in pressure, shall be equal to or less than the below torques:

V*4T		V*6T		V*7T	
Shaft	Max. Torque Nm	Shaft	Max. Torque Nm	Shaft	Max. Torque Nm
1	313	1	392	1	588
11	313	11	568	11	803
86	392	86	588	86	803

### MAXIMUM TORQUE OF THE MOUNTED REAR PUMP

The torque of the mounted pump to the V\*\*T rear pump, in pressure, shall be equal to or less than the indicated torques on next page.

**REAR FLANGE MOUNTING OF THE V\*\*T\* THRU DRIVE PUMP DIMENSIONS**

DIMENSIONS IN MILLIMETRES 1" = 25.4 millimetres

Rear Flange (connection)	Max Torque Nm
A	130
B	315
C	440 (V*6TC) 700 (V*7TC)

**V\*4TA, V\*6TA & V\*7TA**

Torque for screw 65 Nm.

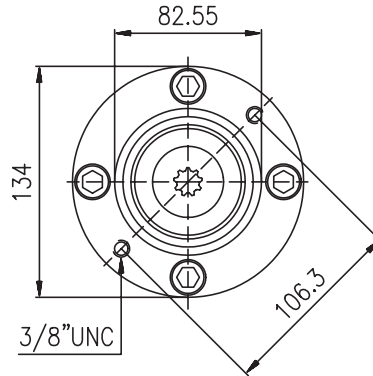

**V\*4TB, V\*6TB & V\*7TB**

Torque for screw 65 Nm.

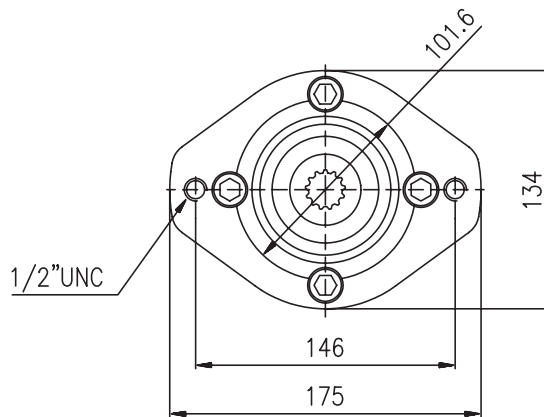

**V\*6TC & V\*7TC**

Torque for screw 65 Nm.

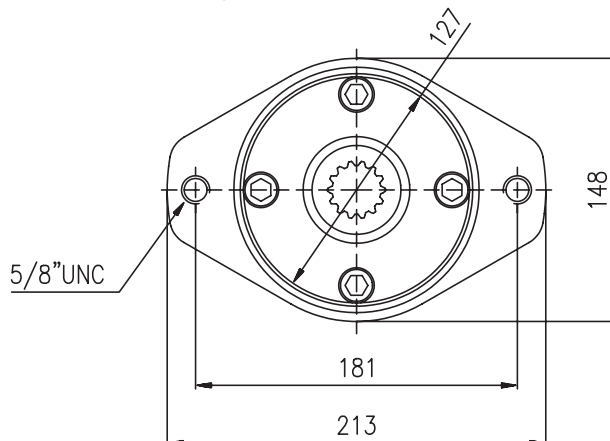

THRU DRIVE PUMPS VS4T & VQ4T

DIMENSIONS IN MILLIMETRES 1" = 25.4 millimetres

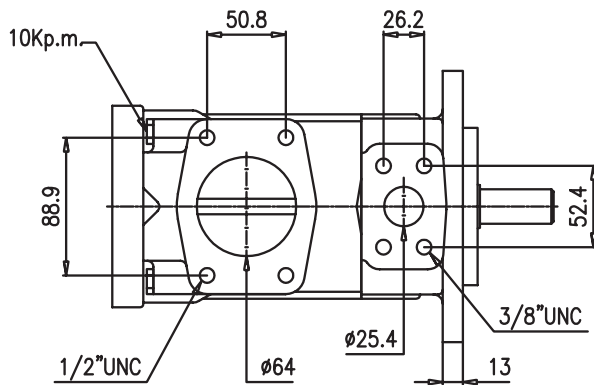
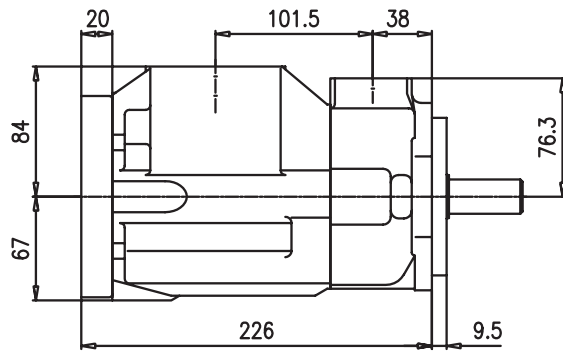
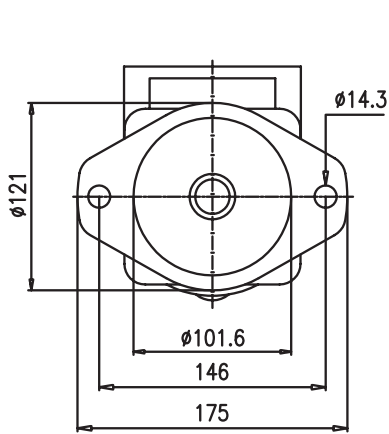
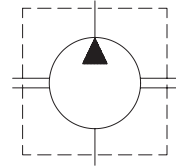

**N°1 Shaft**

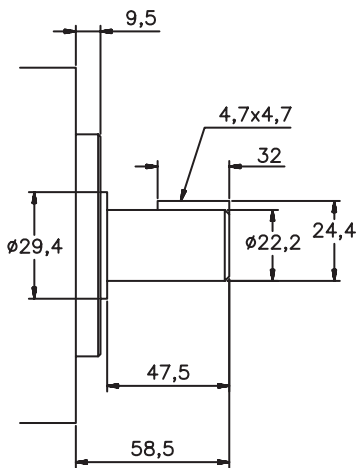

**N°11 Shaft**

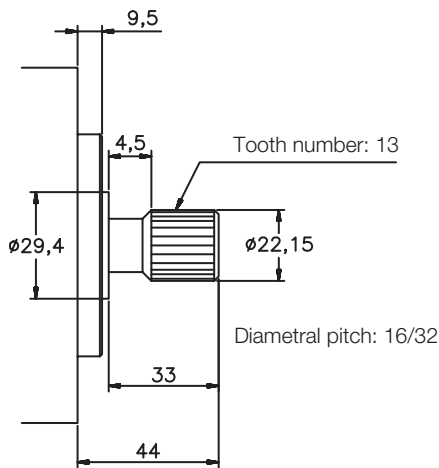

**N°86 Shaft**

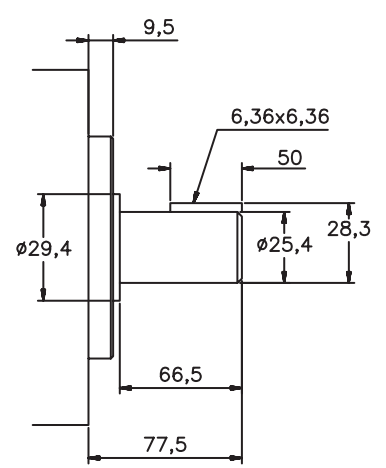

Enquire about other types of shafts

**THRU DRIVE PUMPS VS6T & VQ6T**

DIMENSIONS IN MILLIMETRES 1" = 25.4 millimetres

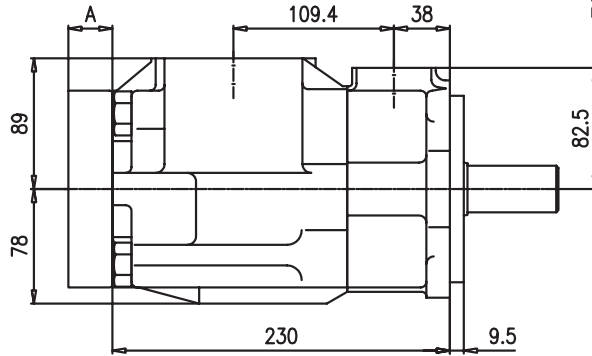
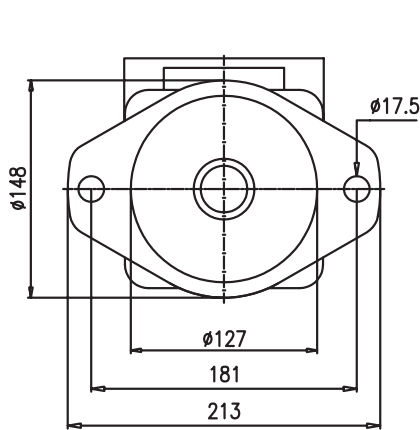
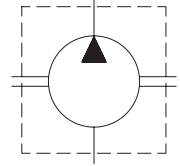

Model	A
V*6TA	20
V*6TB	30
V*6TC	38

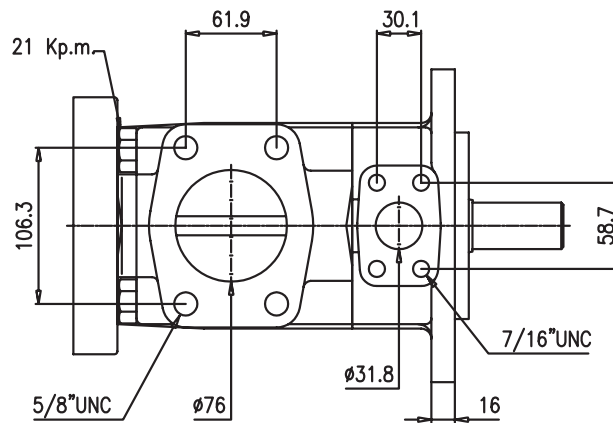

**N°1 Shaft**

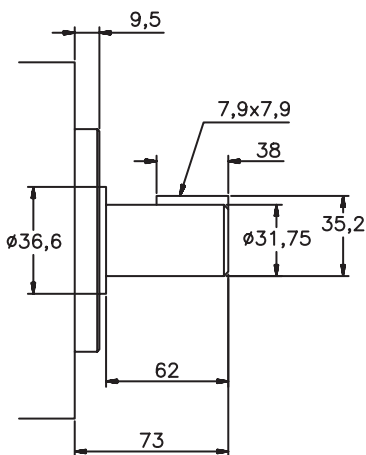

**N°11 Shaft**

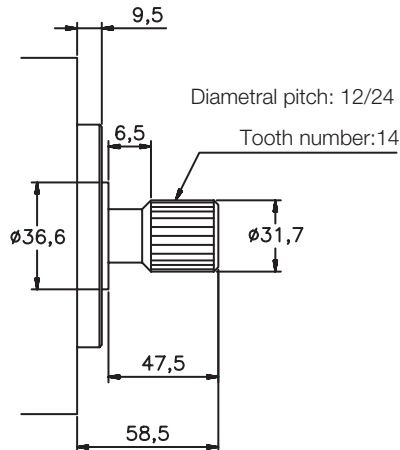

**N°86 Shaft**

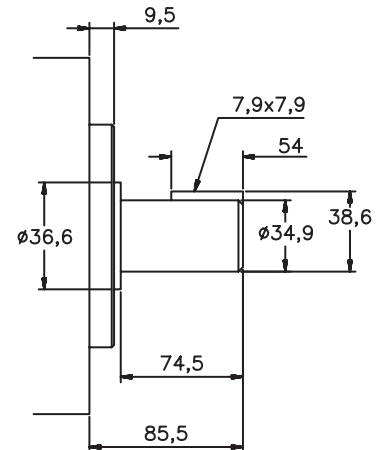

Enquire about other types of shafts

**THRU DRIVE PUMPS VS7T & VQ7T**

DIMENSIONS IN MILLIMETRES 1" = 25.4 millimetres

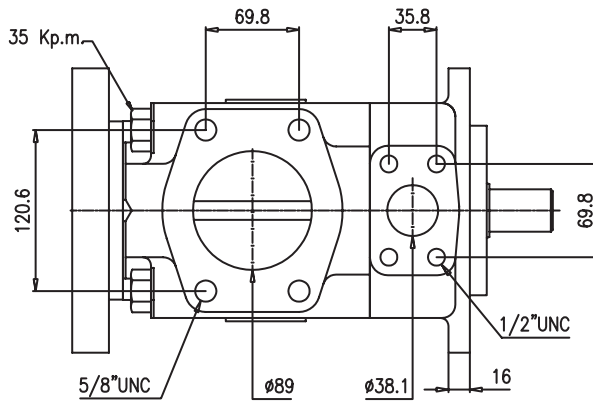
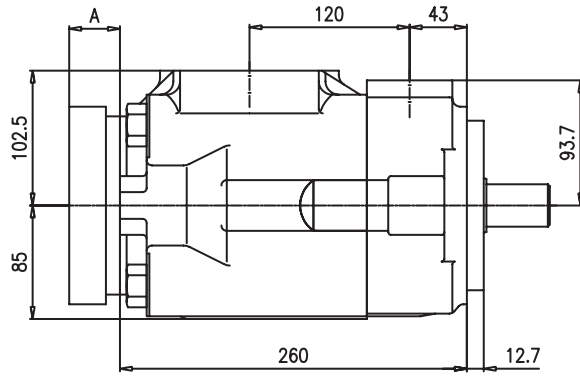
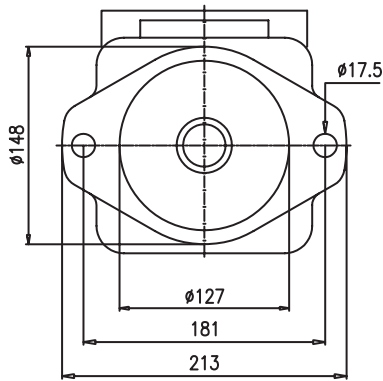
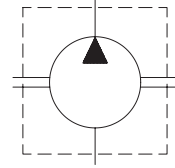

Model	A
V*7TA	20
V*7TB	30
V*7TC	38

**N°1 Shaft**

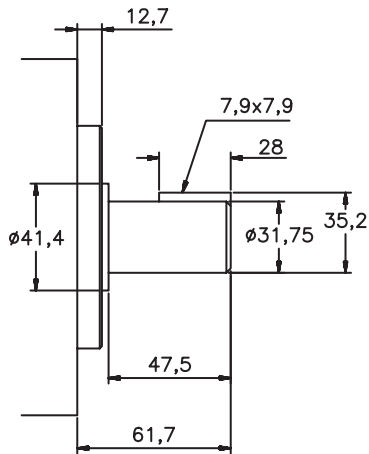

**N°11 Shaft**

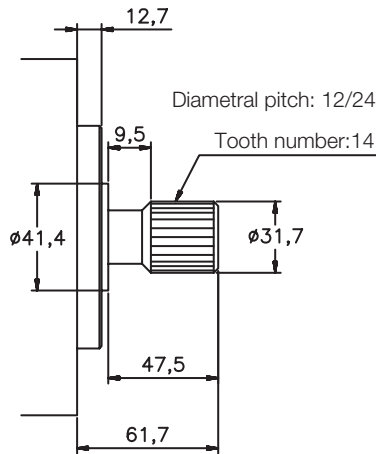

**N°86 Shaft**

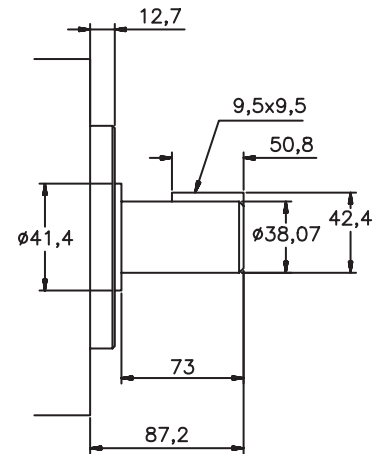

Enquire about other types of shafts



## **DOUBLE VANE PUMPS**

BHP, VQ, VS and DT6 Double vane pumps  
(mobile and industrial applications)

(See single pumps for displacement & power diagrams)

## BHP & V\* DOUBLE VANE PUMPS ORDERING CODE

F3	VS	43	21	8	D	1	A	A
1	2	3	4	5	6	7	8	9

**1 - "F3"** means special seals for fire-resistant fluids. Omit if not required

**2 - Pump Type:**

**BHP = 10 vane pump**, mobile and industrial uses, metrics threads.

**VS = 12 vane pump**, (except the cover end cartridge of the VS\*3 pump), industrial uses (very quiet), UNC threads.

**VQ = 10 vane pump**, bronze plates, mobile uses, UNC threads.

**3 - Model of pump:** 33,42,42V,43,63,64,73,74 y 76.

V\*42 pump may include in the rear cartridge a cover with flow regulating and pressure limiter valves. If so, add one "V": VS42V.

**4 - Pump flow at shaft side:** BHP33 model in litres per minute at 1000 rpm and 7 Bar.

All the other models in US gallons per minute at 1200 rpm and 7 Bar.

(See flow chart).

**5 - Pump flow at cover side:** BHP33 and VS42-VQ42 models in litres per minute

at 1000 rpm and 7 Bar. All the other models in gallons per minute at 1200 rpm and 7 Bar.

(See flow chart).

**6 - D =** Right-hand direction of rotation (Clockwise)

**Y =** Left-hand direction of rotation.

(To check the direction of rotation view from the shaft end).

**7 - Shaft type:**

1: Parallel keyed

2: Splined, (only mounted in BHP 33 model)

11: Splined

86: Heavy duty parallel keyed

**8 - Shaft end outlet position, (viewed from shaft):**

A: Outlet in line with inlet

B: 90° clockwise from inlet

C: 180° from inlet

D: 90° counterclockwise from inlet (Viewed from shaft)

**9- Cover end outlet position, (viewed from shaft):**

A: 45° clockwise from inlet

B: 135° clockwise from inlet

C: 135° counterclockwise from inlet

D: 45° counterclockwise from inlet

(Viewed from shaft)

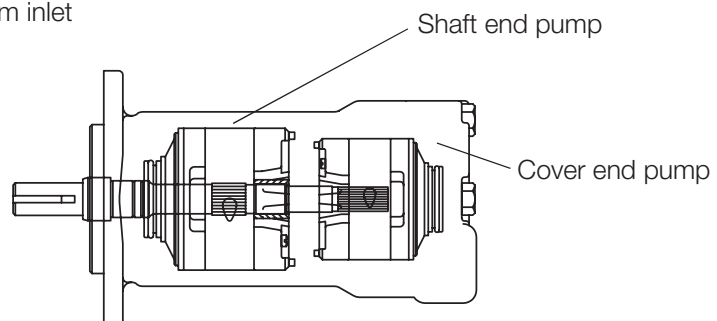



# BHP AND V\* DOUBLE VANE PUMP CHARACTERISTICS

TYPE	SHAFT END							COVER END							WEIGHT (Kgs.)		
	FLOW			MAX. rpm	PRESSURE (Bar)		Nominal Power (3)	FLOW			MAX. rpm	PRESSURE (Bar)		Nominal Power (3)			
	Lts.at 1000 rpm	Gal. At 1200 rpm	Reducc. (2)		Contin.	Intern.		Lts.a 1000 rpm	Gal. a 1200 rpm	Reducc. (2)		Contin.	Intern.				
<b>BHP33</b>	6	2	0,9	2500	150	175	1,9	6	2	0,9	2500	150	175	1,9	15		
	16	5	1,7				4,3	16	5	1,7				4,3			
	18	6	2,8				5,3	18	6	2,8				5,3			
	25	8	4,5				6,9	25	8	4,5				6,9			
	27	9	4,8				7,6	27	9	4,8				7,6			
	35	11	4,8	8,8	35	11	4,8	8,8									
	38	12	5,4	10,2	38	12	5,4	10,2									
	44	14	6,6	11,9	44	14	6,6	11,9									
	50	16	7,8	13,6	50	16	7,8	13,6									
	2000																
1500	100	125									100	125					
<b>VS42 VQ42 (1)</b>	26	8	4,5	2500	175	210	6,9	7	2,2	0,7	2500	150	175	1,8	16		
	40	12	5,7				10,4										
	45	14	5,7				11,6										
	55	17	5,8				13,8										
	60	19	5,8				15,2										
	67	21	6	16,8													
	80	24	6,2	20,3													
	88*	27	6,5	22,4													
	1500	125	150														
	<b>VS43 VQ43</b>	26	8	4,5	2500	175	210	6,9	8	2	0,9	2500	175	210		1,9	21
40		12	5,7	10,4													
45		14	5,7	11,6													
55		17	5,8	13,8													
60		19	5,8	15,2													
67		21	6	16,8													
80		24	6,2	20,3													
88*		27	6,5	22,4													
1500		125	150														
<b>VS63 VQ63</b>		66	21	8,6	2400	175	210	16,8	8	2	0,9	2500	175	210	1,9	31	
	81	25	9	20,3													
	97	30	10	24,3													
	112	35	11,4	27,4													
	121	38	11,4	29,3													
	142	45	13,1	33,3													
	1500	125	150														
	<b>VS64 VQ64</b>	66	21	8,6	2400	175	210	16,8	26	8	4,5	2500	175	210	6,9		33
		81	25	9				20,3									
		97	30	10				24,3									
112		35	11,4	27,4													
121		38	11,4	29,3													
142		45	13,1	33,3													
1500		125	150														
<b>VS73 VQ73</b>		138	42	15	2200	155	175	32,3	8	2	0,9	2500	175	210	1,9	46	
		148	47	15,7				36,3									
		162	50	14,3				37,9									
	180	57	17,9	43,2													
	193	60	18,6	46,1													
	214	67	22	51,2													
	240	75	26	57,4													
	1500	125	150														
	<b>VS74 VQ74</b>	138	42	15	2200	155	175	32,3	26	8	4,5	2500	175	210	6,9		45
		148	47	15,7				36,3									
162		50	14,3	37,9													
180		57	17,9	43,2													
193		60	18,6	46,1													
214		67	22	51,2													
240		75	26	57,4													
1500		125	150														
<b>VS76 VQ76</b>		138	42	15	2200	155	175	32,3	66	21	8,6	2400	175	210	16,8	55	
		148	47	15,7				36,3									
	162	50	14,3	37,9													
	180	57	17,9	43,2													
	193	60	18,6	46,1													
	214	67	22	51,2													
	240	75	26	57,4													
	1500	125	150														

\* 27 gallons (88lbs.) cartridge not mounted in **VQ42, VQ43, VQ64, VQ74** vane pump model.  
 (1), (2) & (3) Please turn to next page

**DOUBLE VANE PUMPS BHP-33**

DIMENSIONS IN MILLIMETRES 1" = 25.4 millimetres

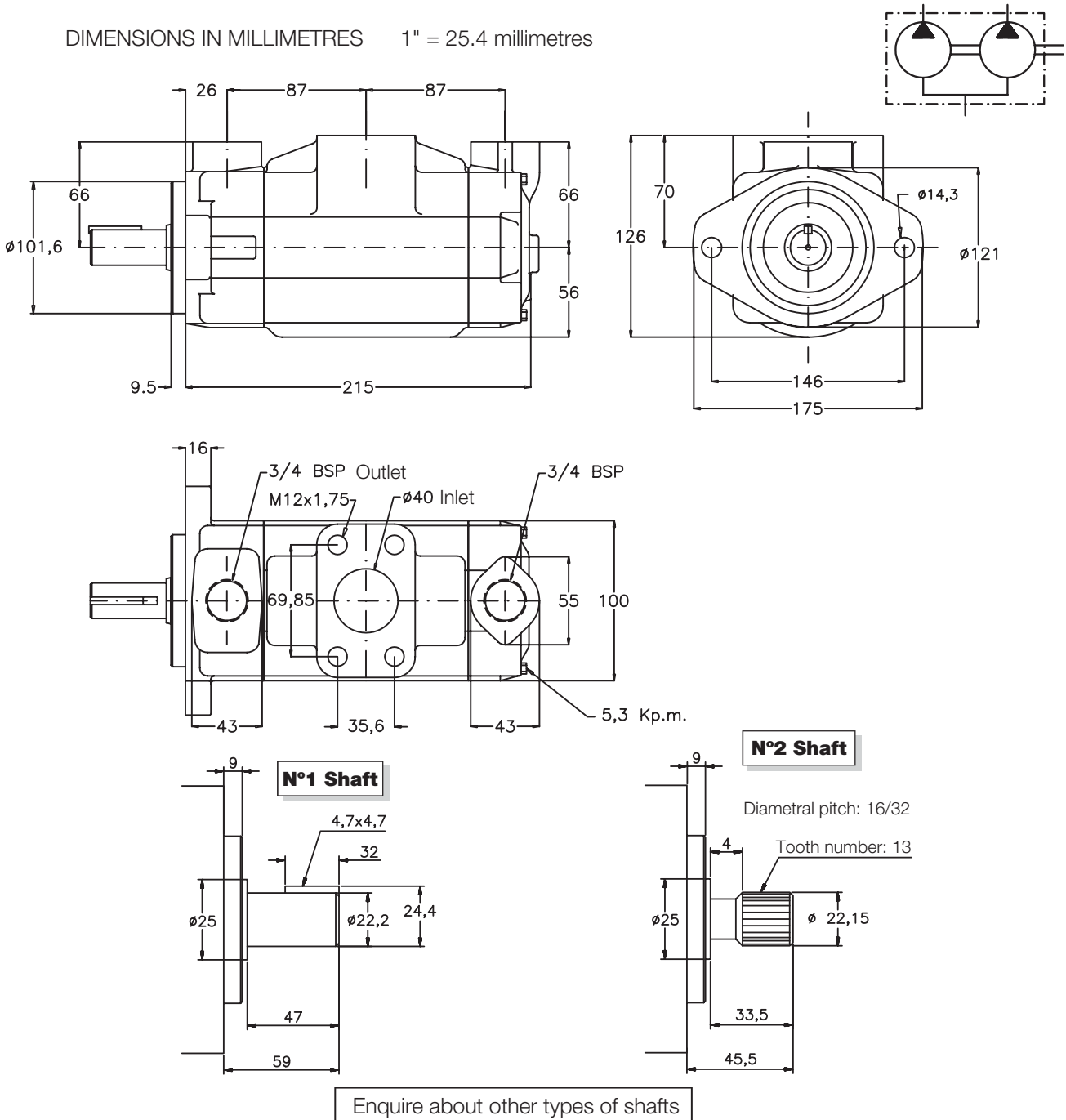

**Continued from previous page:**

- (1) There is a version for the pump of the cover end with flow regulating and pressure limiter valves whose reference V\*42V
- (2) **Delivery flow reduction** in Ltrs./min. at 100 Bar. 22 cST of oil viscosity at operating temperature. To calculate the approximate delivery flow at a given pressure and speed, use the following formula with flow reduction and theoretical flow values shown in the chart. Flow reduction values are independent of shaft speed.

$$\text{Approx. output flow (Ltrs./min.)} = \text{Theoretical flow} \times \frac{\text{R.P.M}}{1000} \times \frac{\text{Pressure (bar)}}{100}$$

- (3) **Nominal power** in H.P. at 100 Bar and 1000 RPM (to convert into Kw multiply by 0.735). To get the real input power at different pressure and revolutions, use the formula as follows:

$$\text{Real input power} = \text{Input power} \times \frac{\text{R.P.M}}{1000} \times \frac{\text{Pressure (bar)}}{100}$$

**DOUBLE VANE PUMPS VS-42 Y VQ-42**

DIMENSIONS IN MILLIMETRES 1" = 25.4 millimetres

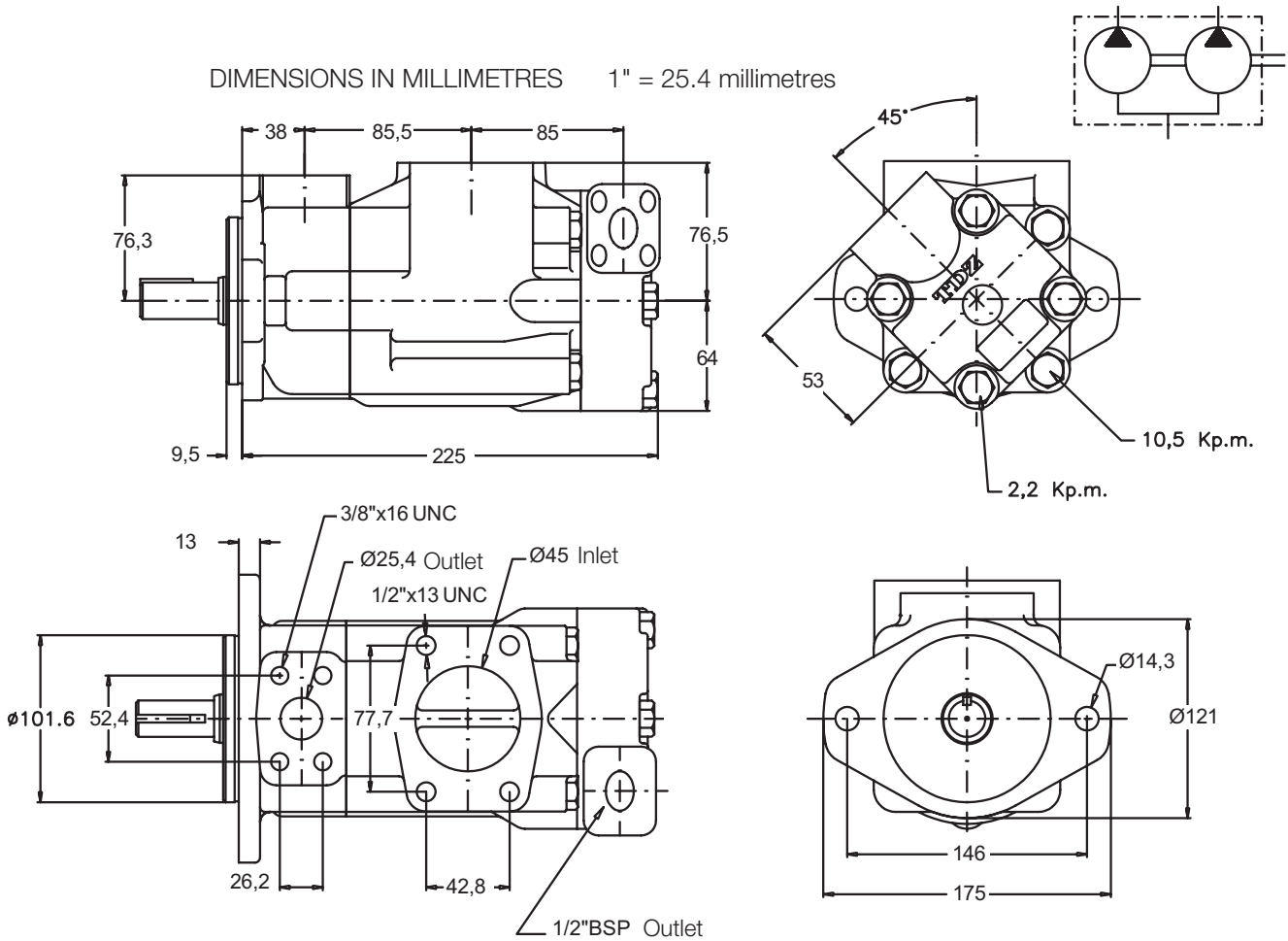

**N°1 Shaft**

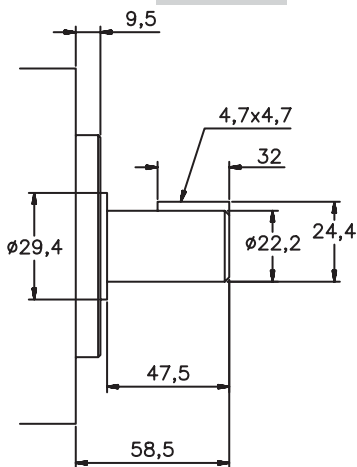

**N°11 Shaft**

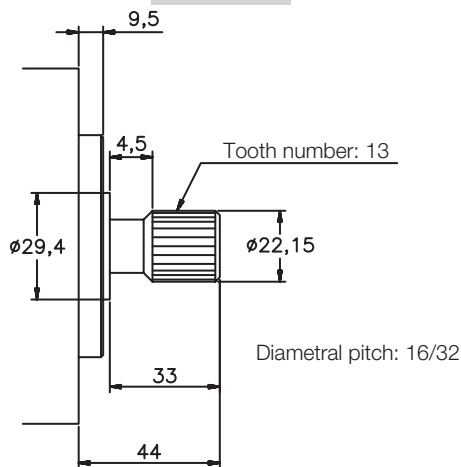

**N°86 Shaft**

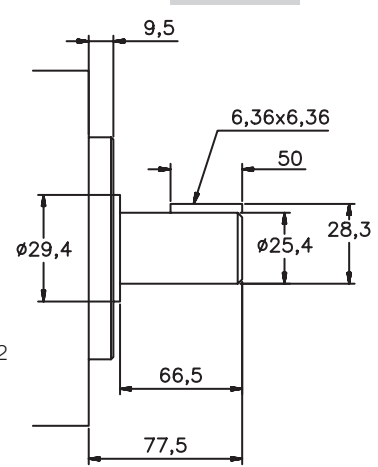

Enquire about other types of shafts

There is a version for the pump of the cover end with flow regulating and pressure limiter valves whose reference V\*42V

**DOUBLE VANE PUMPS VS-43 Y VQ-43**

DIMENSIONS IN MILLIMETRES 1" = 25.4 millimetres

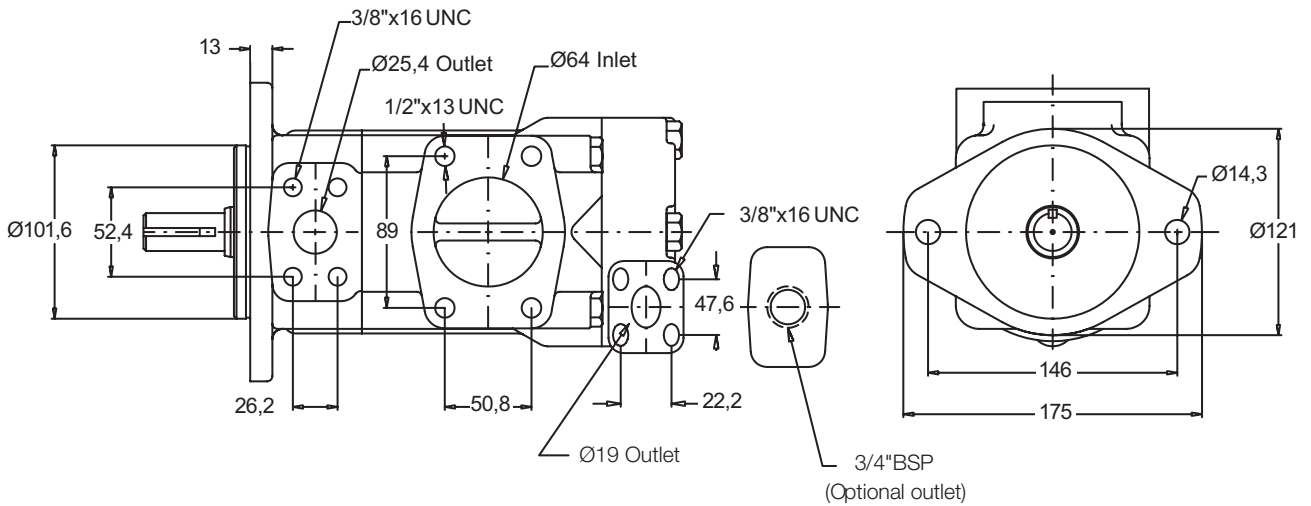
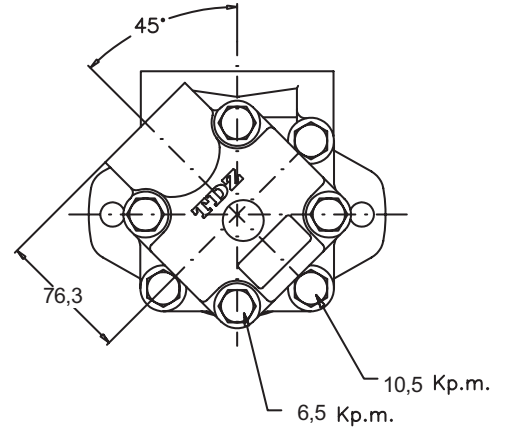
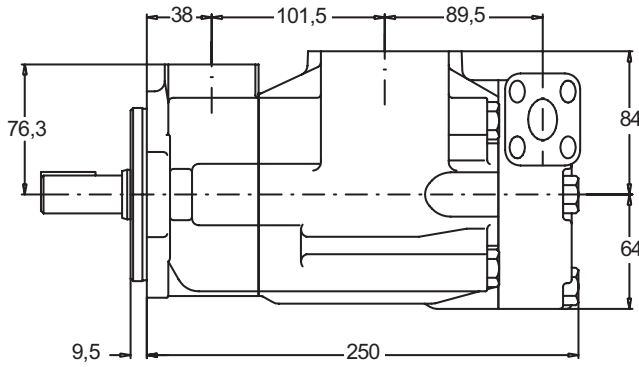
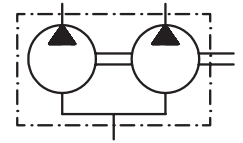

**N°1 Shaft**

**N°11 Shaft**

**N°86 Shaft**

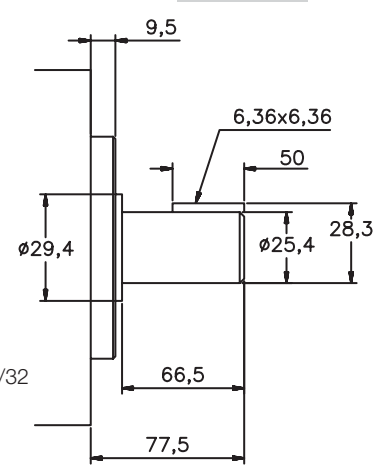
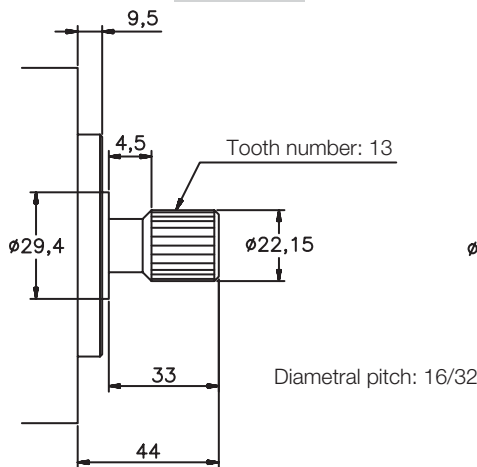
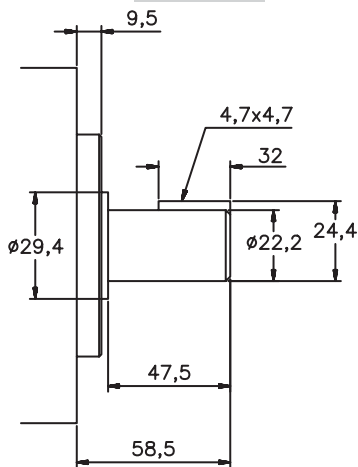

Enquire about other types of shafts

**DOUBLE VANE PUMPS VS-63 Y VQ-63**

DIMENSIONS IN MILLIMETRES 1" = 25.4 millimetres

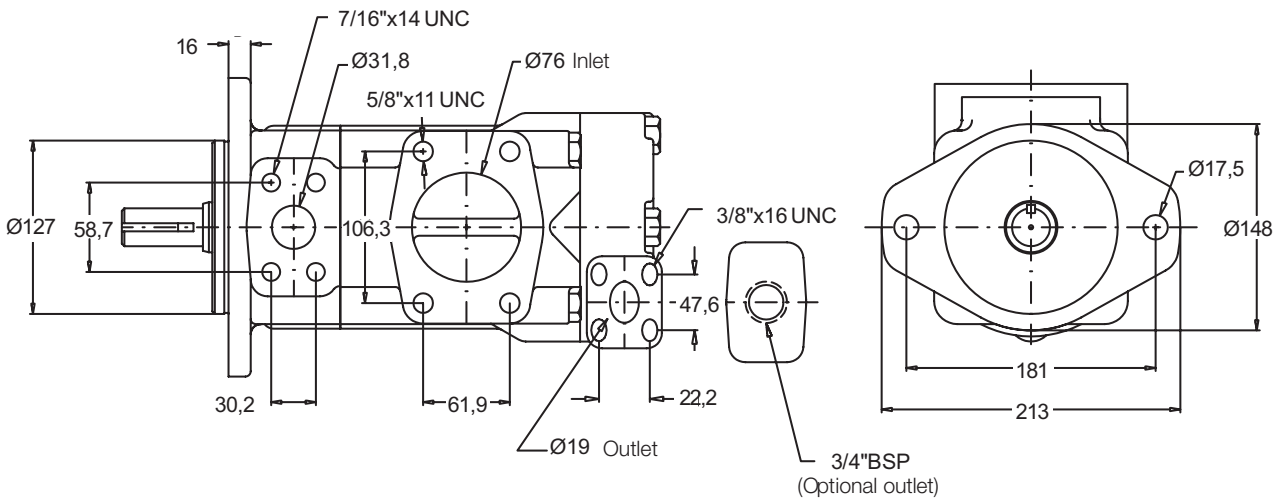
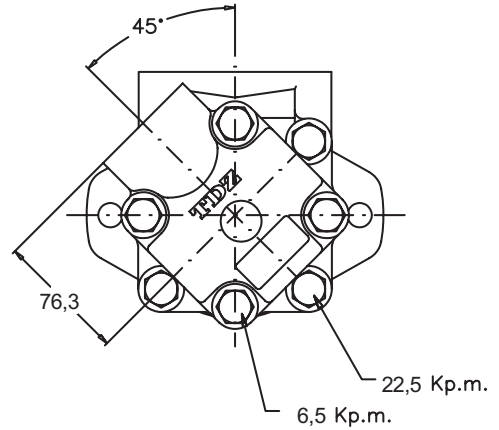
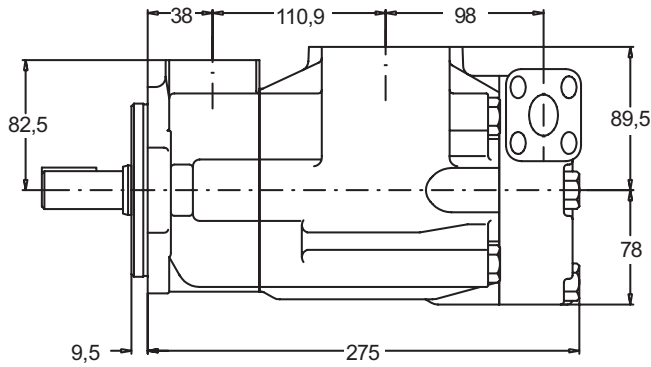

**N°1 Shaft**

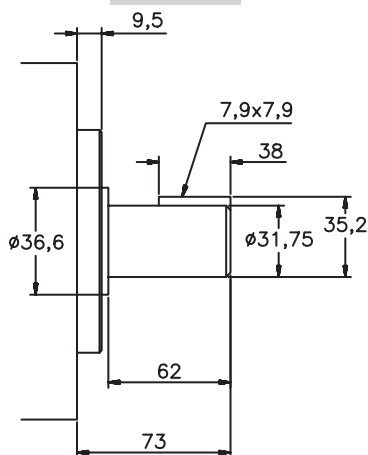

**N°11 Shaft**

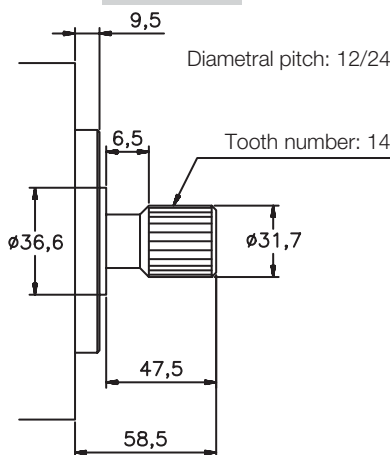

**N°86 Shaft**

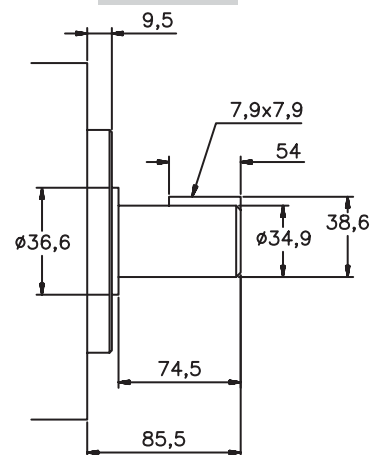

Enquire about other types of shafts

**DOUBLE VANE PUMPS VS-64 Y VQ-64**

DIMENSIONS IN MILLIMETRES 1" = 25.4 millimetres

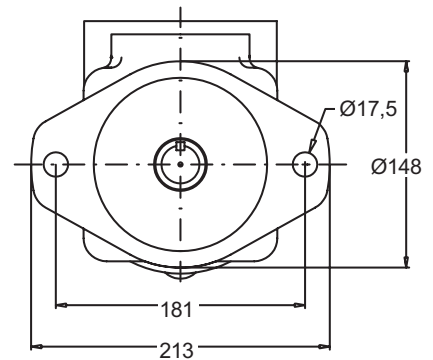
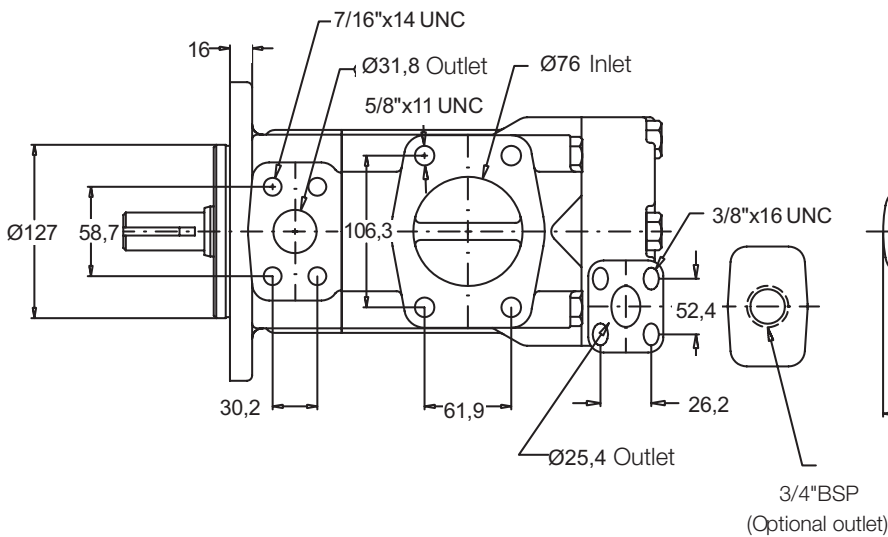
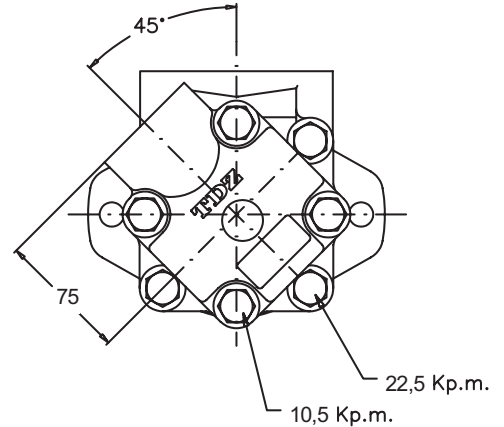
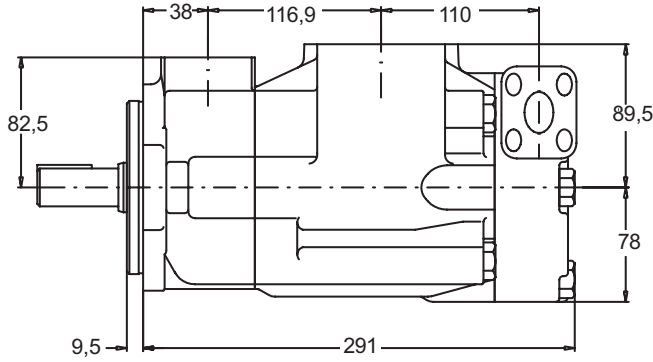
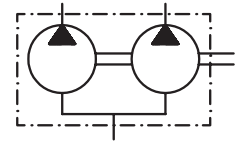

**N°1 Shaft**

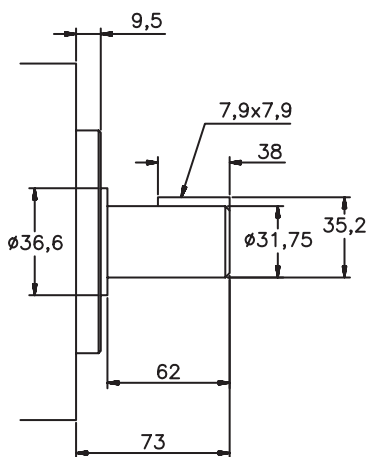

**N°11 Shaft**

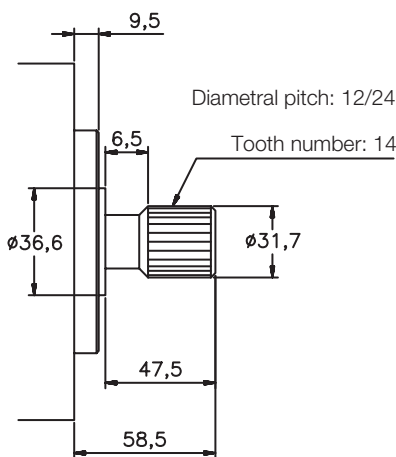

**N°86 Shaft**

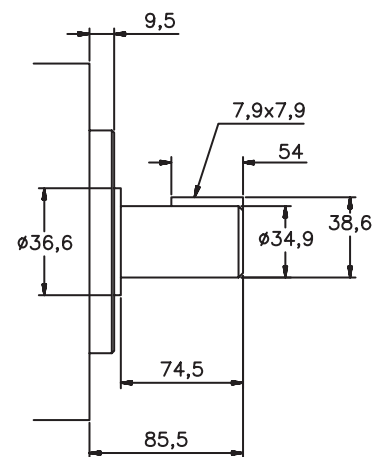

Enquire about other types of shafts

**DOUBLE VANE PUMPS VS-73 Y VQ-73**

DIMENSIONS IN MILLIMETRES 1" = 25.4 millimetres

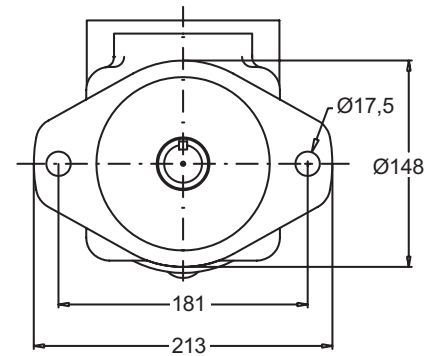
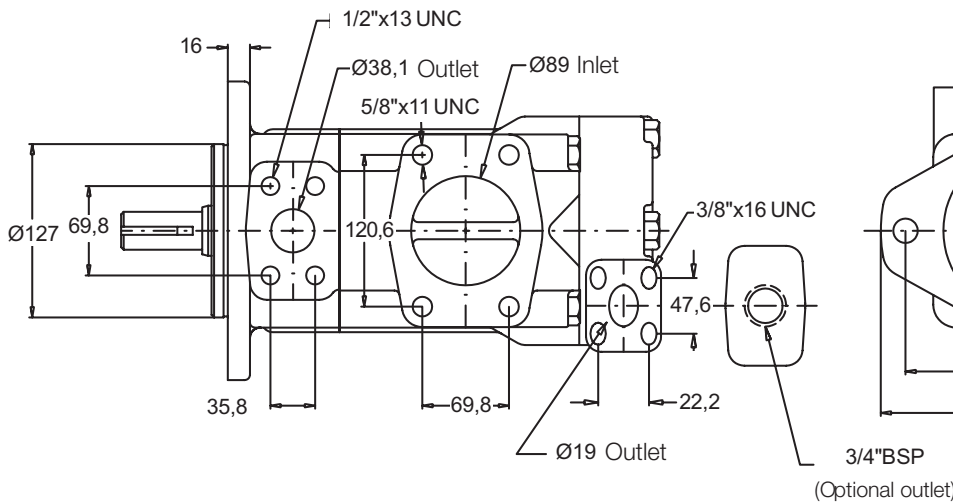
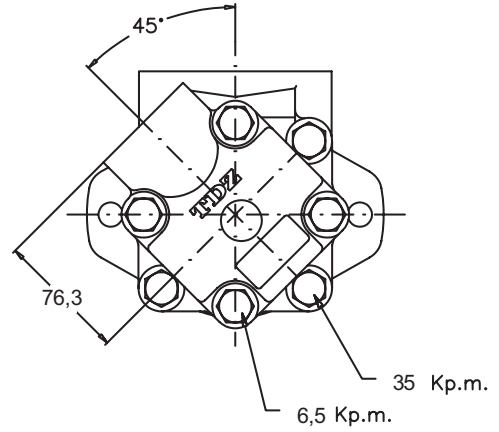
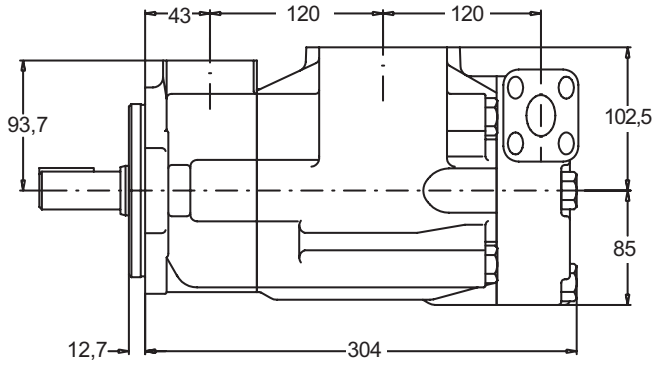

**N°1 Shaft**

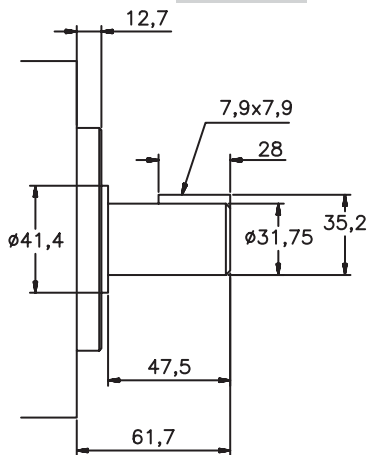

**N°11 Shaft**

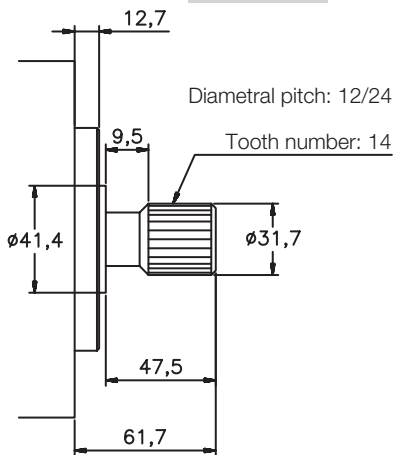

**N°86 Shaft**

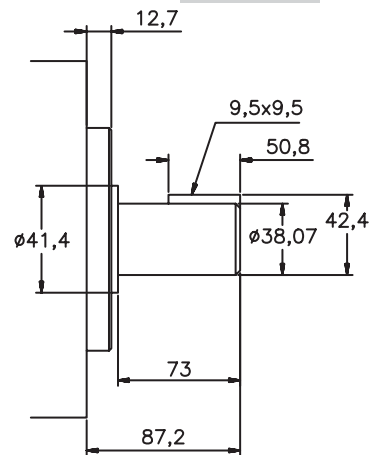

Enquire about other types of shafts

**DOUBLE VANE PUMPS VS-74 Y VQ-74**

DIMENSIONS IN MILLIMETRES 1" = 25.4 millimetres

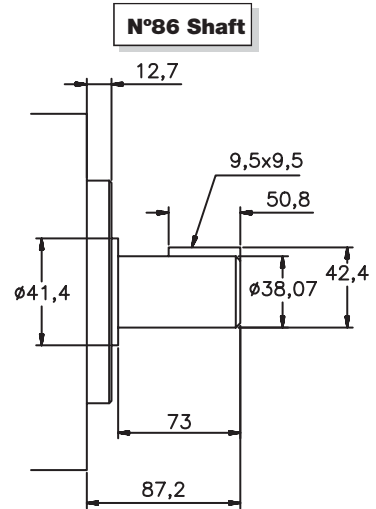
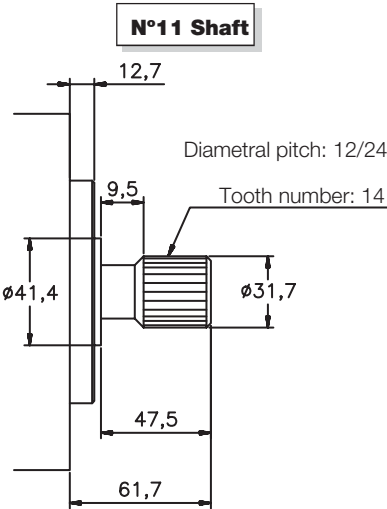
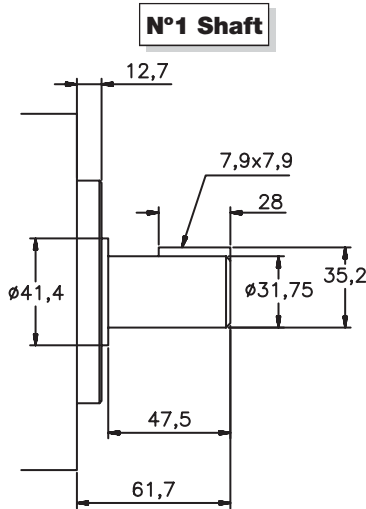
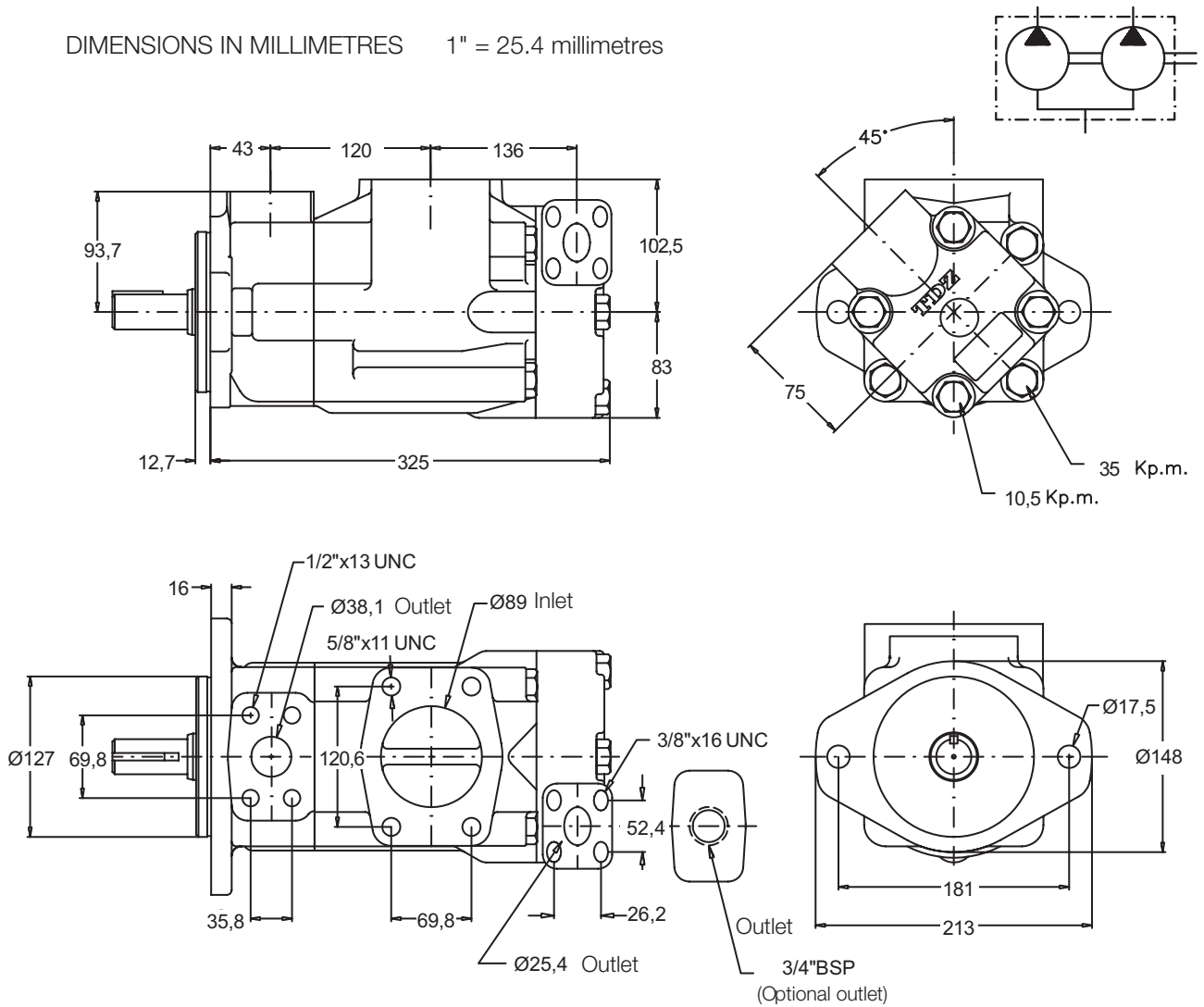

Enquire about other types of shafts





## DT6 DOUBLE VANE PUMPS ORDERING CODE

**DT6\* - CC - \* - B -17/14 - 1 - R - 00 - B - 1 - M - 00**

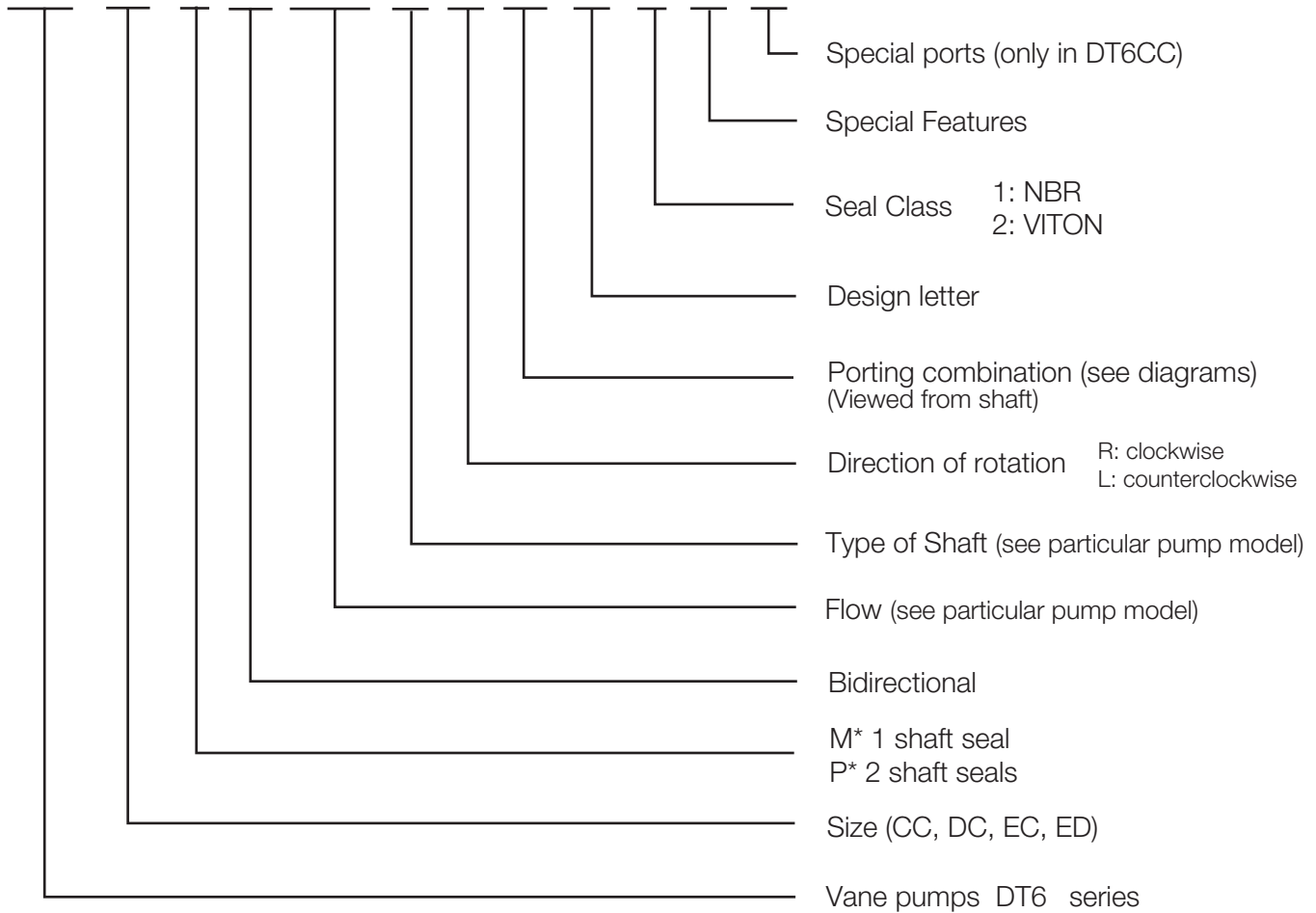

# GENERAL CHARACTERISTICS

## DOUBLE VANE PUMPS

Pump Model	P1			P2			Maxim. speed	Minim. speed	Front flange standard SAE j744c ISO 3019-1	Weight Kgs	SAE 4 Holes flange		
	Cartridge Model	Theoretical displacement Cm <sup>3</sup> /rev	Maxim. Pressure Bar	Cartridge Model	Theoretical displacement Cm <sup>3</sup> /rev	Maxim. Pressure Bar					Suction S	Pressure	
												P1	P2
<b>DT6CC/M</b>	003 a 031	10.8 a 100	275	003 a 031	10.8 a 100	275	2800	400	SAE B	26	2 1/2" x 3"	1"	1" x 3/4"
<b>DT6DC/M</b>	014 a 061	47.6 a 190.5	240	003 a 031	10.8 a 100	275	2800	400	SAE C	37	3"	1 1/4"	1"
<b>DT6EC/M</b>	042 a 085	132.3 a 269.8	240	003 a 031	10.8 a 100	275	2200	400	SAE C	55	3 1/2"	1 1/2"	1"
<b>DT6ED/M</b>	042 a 085	132.3 a 268.8	240	014 a 061	47.6 a 190.5	240	2200	400	SAE C	66	4"	1 1/2"	1"

C - 025,028,031 - 2500 rpm maximum 028,031 - 210 bar max intermittent  
 D - 042,045,050 - 2200 rpm maximum 050 - 210 bar maximum intermittent - 061 - 120 bar maximum intermittent  
 E - 085 - 2000 rpm maximum - 90 bar maximum intermittent

Above mentioned values of maximum speed and maximum pressure are based on use of antiwear oil only. Please contact **TDZ** for particular values when different fluids are used, (synthetic fluids, water in oil emulsions, water glycol, etcetera)

## DOUBLE VANE PUMPS - PORTING COMBINATION DT6CC-DT6DC-DT6EC

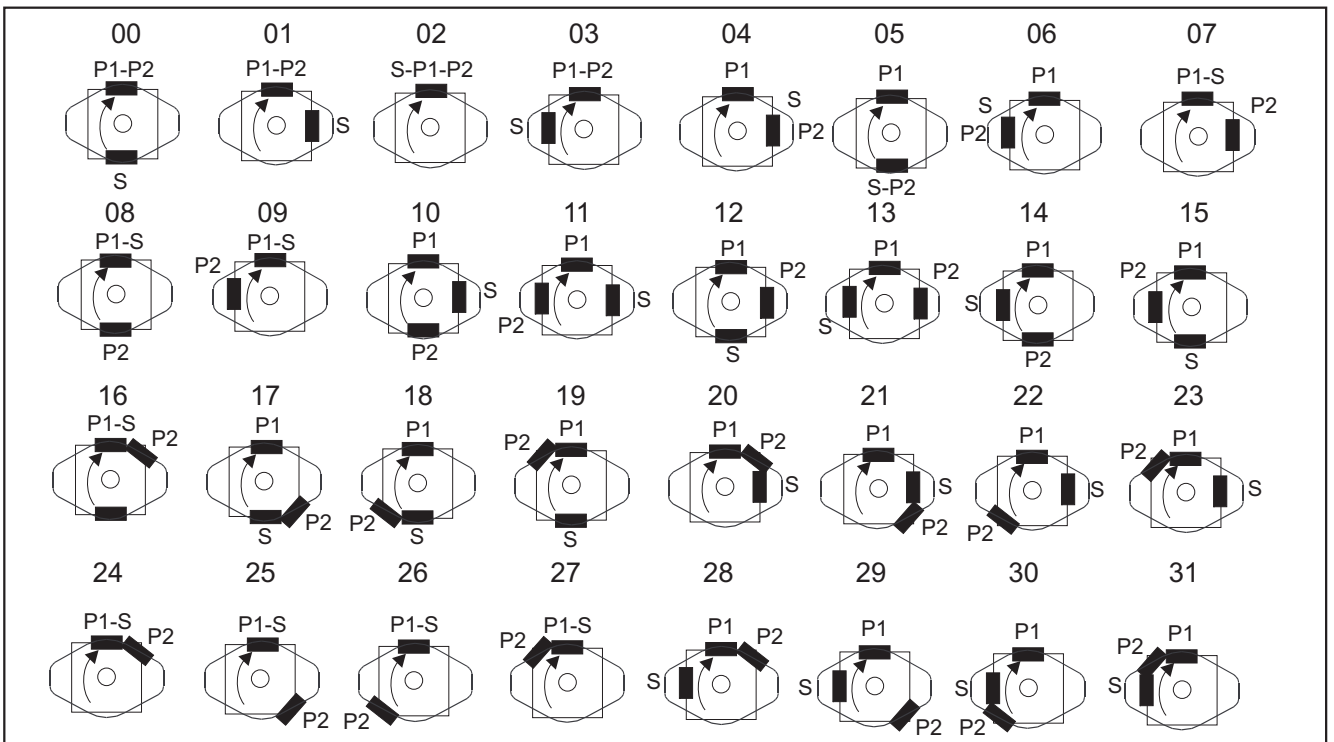

## DOUBLE VANE PUMPS - PORTING COMBINATION DT6ED

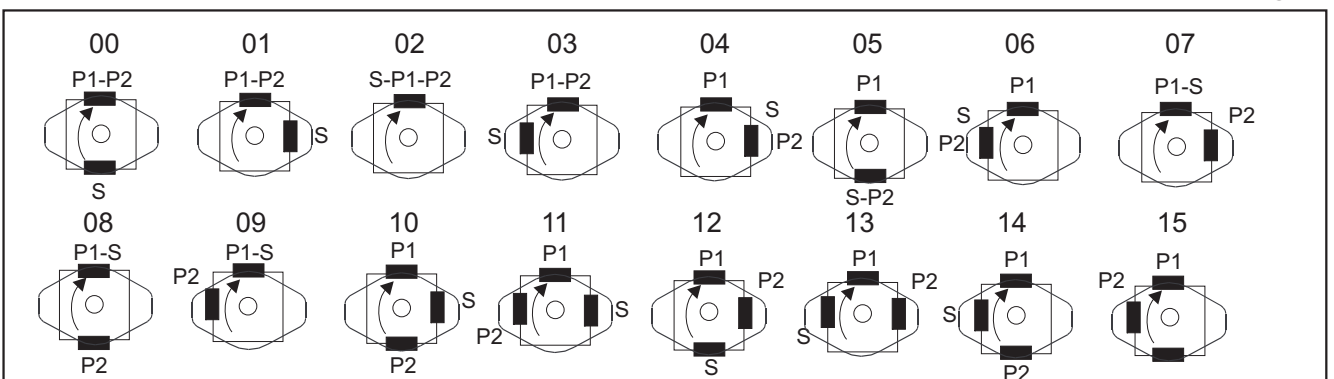

**S= Suction port | P1= Shaft end pressure port | P2= Cover end pressure port**

**DOUBLE PUMPS DT6CC - OPERATING CHARACTERISTICS**

**SHAFT END SECTION**

FLOW											SPEED (rpm)		PRESSURE (bar)		WEIGHT			
											Mín.	Máx.	Intermit.	Contin.	(Kgs.)			
Lts/min.at 1000 rpm	11	17	21	26	34	37	46	58	64	70	79	89	100	400	2800*	275	240*	15
Gal/min.at 1200 rpm	3	5	6	8	10	12	14	17	20	22	25	28	31	400	2800*	275	240*	15

\* See page 41 for further information about speed & pressure.

**COVER END SECTION**

FLOW											SPEED (rpm)		PRESSURE (bar)		WEIGHT			
											Mín.	Máx.	Intermit.	Contin.	(Kgs.)			
Lts/min.at 1000 rpm	11	17	21	26	34	37	46	58	64	70	79	89	100	400	2800*	275	240*	15
Gal/min.at 1200 rpm	3	5	6	8	10	12	14	17	20	22	25	28	31	400	2800*	275	240*	15

\* See page 41 for further information about speed & pressure.

**DT6CC - FLOW & INPUT POWER DIAGRAMS**

**SHAFT END**

See **DT6C** Single Pumps for flow and input power diagrams (page 42)

**COVER END**

See **DT6C** Single Pumps for flow and input power diagrams (page 42)

**DOUBLE PUMPS DT6CC - DIMENSIONS**

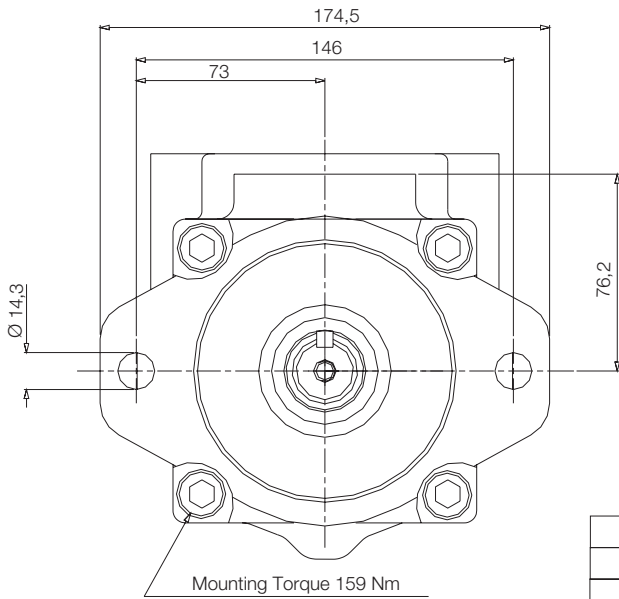

**Suction and pressure Port dimension variables.**

Thread	Port	A	B	C	D	E
S	3	106,4	61,9	76,2		5/8 -11UNC x 28,4
S	2 1/2	88,9	50,8	63,5		1/2 -13UNC x 23,9
P1	1	52,4	26,2	25,4	76,2	
P2	3/4	47,7	22,4	19,0	76,2	
P2	1	52,4	26,2	25,4	74,7	

**\*Add the following numbers at the end of the DT6CC reference depending your option.**

	Code 00*	Code 01*	Code 10*	Code 11*
S	3	3	2 1/2	2 1/2
P1	1	1	1	1
P2	1	3/4	1	3/4

You may use suction S of 2 1/2 for 126 cc/rev. maximum  
You may use pressure port P2 of 3/4 for 46 cc/rev. maximum

Pump	Shaft code	Shaft torque limits cc/rev x bar V x P max (P1+P2)
<b>DT6CC</b>	1	14300
	3	32670
	5	20600
<b>DT6CCW</b>	2	21470

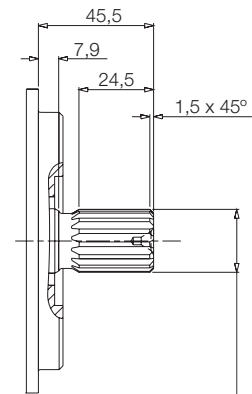
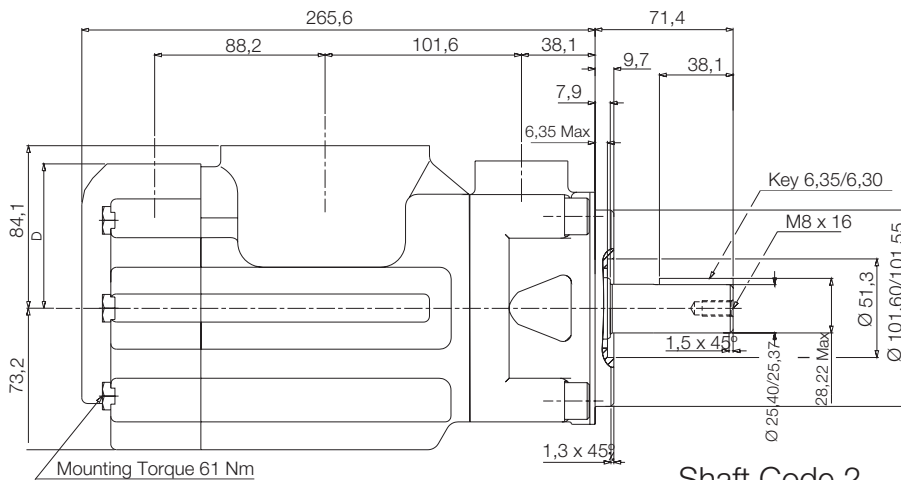

**Shaft Code 3**

SAE BB Splined shaft  
1-J498b 16/32 d.p. -  
15 Teeth  
30° Pressure angle

**Shaft Code 2**

SAE BB

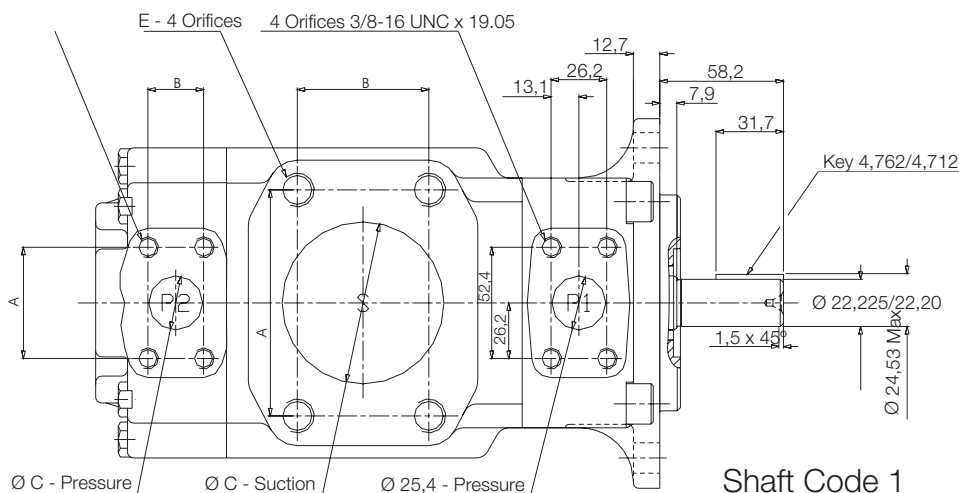

**Shaft Code 1**

Keyed no SAE

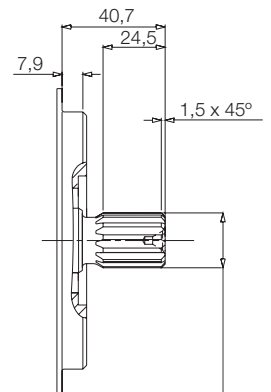

**Shaft Code 5**

SAE B Splined shaft  
1-J498b 16/32 d.p. -  
13 Teeth  
30° Pressure angle

**DT6DC - OPERATING CHARACTERISTICS**

**SHAFT END SECTION**

FLOW											SPEED (rpm)		PRESSURE (bar)		WEIGHT	
											Mín.	Máx.	Intermit.	Contin.	(Kgs.)	
<b>Lts/min.at 1000 rpm</b>	48	66	80	90	98	111	120	136	146	158	191	400	2500*	240	210	24
<b>Gal/min.at 1200 rpm</b>	14	20	24	28	31	35	38	42	45	50	61	400	2500*	240	210	24

\* See page 41 for further information about speed & pressure.

**COVER END SECTION**

FLOW											SPEED (rpm)		PRESSURE (bar)		WEIGHT	
											Mín.	Máx.	Intermit.	Contin.	(Kgs.)	
<b>Lts/min.at 1000 rpm</b>	11	17	21	26	34	37	46	58	64	70	79	89	100	275	240*	15
<b>Gal/min.at 1200 rpm</b>	3	5	6	8	10	12	14	17	20	22	25	28	31	275	240*	15

\* See page 41 for further information about speed & pressure.

**DT6DC - FLOW & INPUT POWER DIAGRAMS**

**SHAFT END**

See **DT6D** Single Pumps for flow and input power diagrams (page 44)

**COVER END**

See **DT6C** Single Pumps for flow and input power diagrams (page 42)

**DOUBLE PUMPS DT6DC - DIMENSIONS**

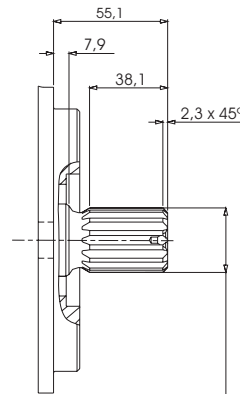
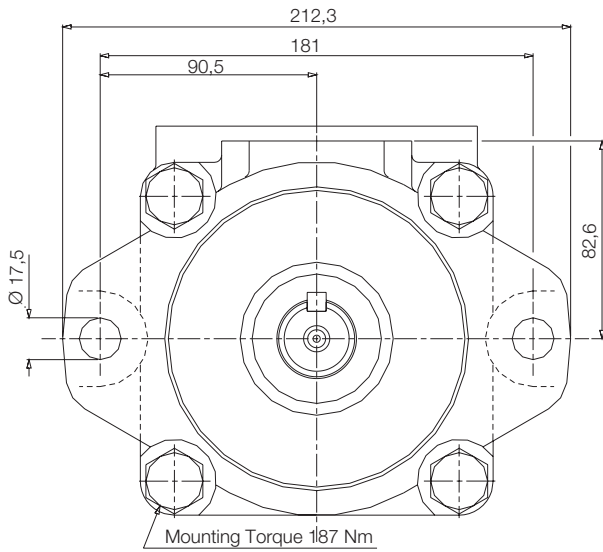

**Shaft Code 3**

SAE C Splined shaft  
1-J498b 12/24 d.p. -  
14 Teeth  
30° Pressure angle

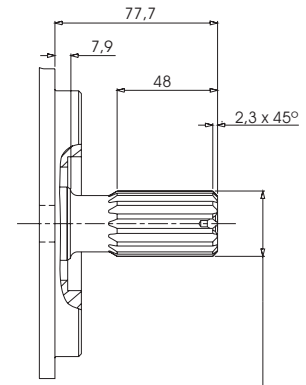

**Shaft Code 4**

Splined no SAE shaft  
1-J498b 12/24 d.p. -  
14 Teeth  
30° Pressure angle

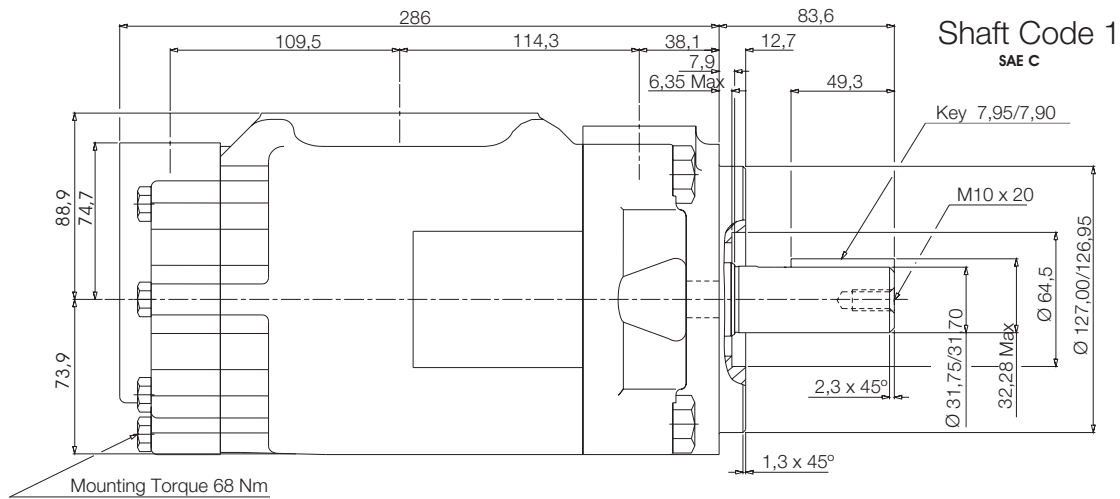

**Shaft Code 1**

SAE C

Shaft Torque Limits (cc/rev x bar)		
Pumps	Shaft code	V x P max (P1+P2)
<b>DT6DC</b>	1	43240
	2	38996

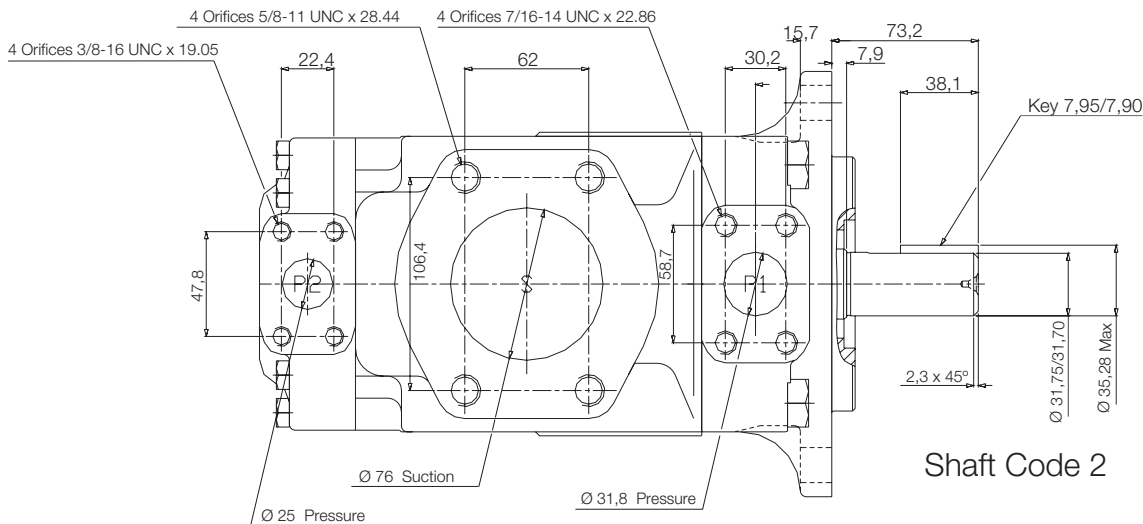

## DT6EC - OPERATING CHARACTERISTICS

### SHAFT END SECTION

	FLOW								SPEED (rpm)		PRESSURE (bar)		WEIGHT (Kgs.)
	Lts/min.at 1000 rpm	132	142	156	165	197	213	227	270	Mín.	Máx.	Intermit.	
Gal/min.at 1200 rpm	42	45	50	52	62	66	72	85	400	2200*	240	210	44

\* See page 41 for further information about speed & pressure.

### COVER END SECTION

	FLOW												SPEED (rpm)		PRESSURE (bar)		WEIGHT (Kgs.)	
	Lts/min.at 1000 rpm	11	17	21	26	34	37	46	58	64	70	79	89	100	Mín.	Máx.		Intermit.
Gal/min.at 1200 rpm	3	5	6	8	10	12	14	17	20	22	25	28	31	400	2800*	275	240*	15

\* See page 41 for further information about speed & pressure.

## DT6EC - FLOW & INPUT POWER DIAGRAMS

### SHAFT END

See **DT6E** Single Pumps for flow and input power diagrams (page 46)

### COVER END

See **DT6C** Single Pumps for flow and input power diagrams (page 42)



**DOUBLE PUMPS DT6EC - DIMENSIONS**

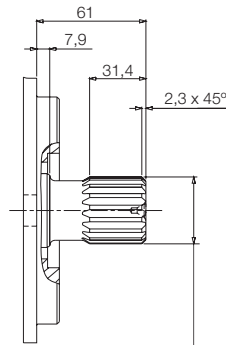
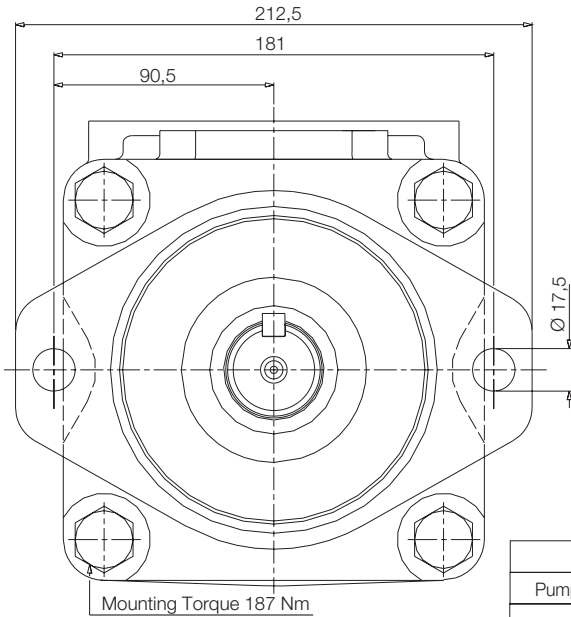

**Shaft Code 4**

SAE CC Splined shaft  
1-J498b 12/24 d.p. -  
17 Teeth  
30° Pressure angle

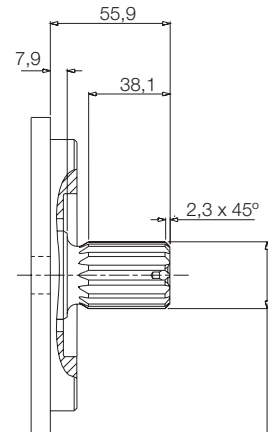

**Shaft Code 3**

SAE C Splined shaft  
1-J498b 12/24 d.p. -  
14 Teeth  
30° Pressure angle

Shaft Torque Limits (cc/rev x bar)		
Pump	Shaft Code	V x P max (P1+P2)
<b>DT6EC</b>	1	72306
	2	34590
	3	61200

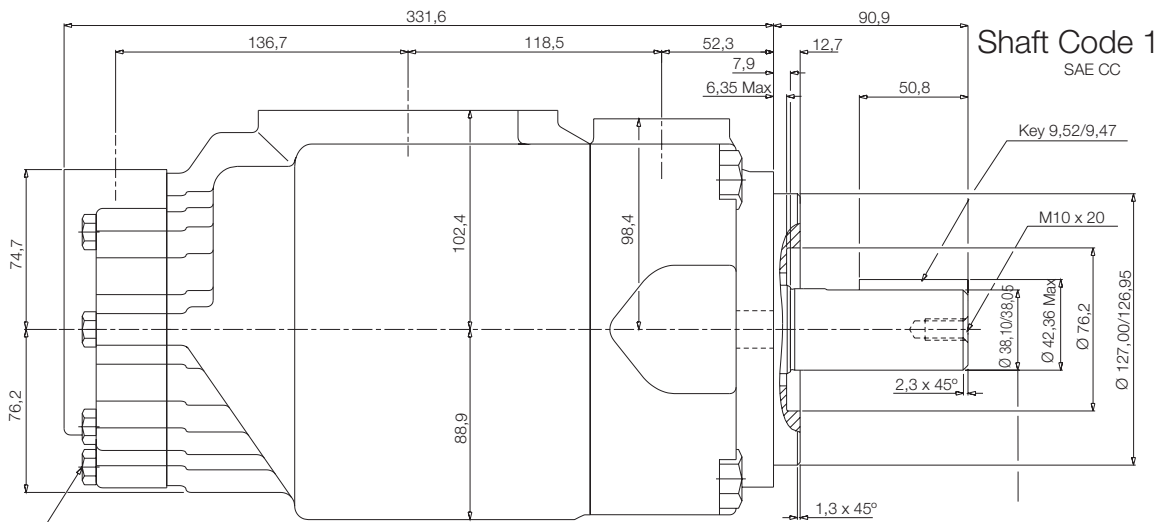

**Shaft Code 1**  
SAE CC

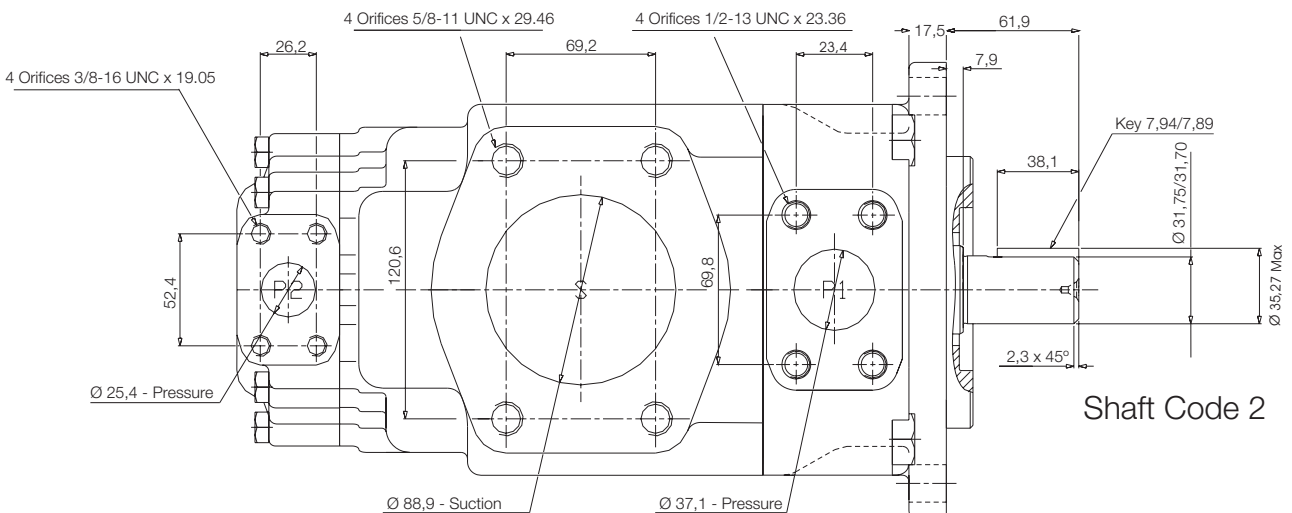

**Shaft Code 2**

**DT6ED - OPERATING CHARACTERISTICS**

**SHAFT END SECTION**

FLOW									SPEED (rpm)		PRESSURE (bar)		WEIGHT (Kgs.)
Lts/min.at 1000 rpm	132	142	156	165	197	213	227	270	Mín.	Máx.	Intermit.	Contin.	
Gal/min.at 1200 rpm	42	45	50	52	62	66	72	85	400	2200*	240	210	44

\* See page 41 for further information about speed & pressure.

**COVER END SECTION**

FLOW												SPEED (rpm)		PRESSURE (bar)		WEIGHT (Kgs.)
Lts/min.at 1000 rpm	48	66	80	90	98	111	120	136	146	158	191	Mín.	Máx.	Intermit.	Contin.	
Gal/min.at 1200 rpm	14	20	24	28	31	35	38	42	45	50	61	400	2500*	240	210	24

\* See page 41 for further information about speed & pressure.

**DT6ED - FLOW & INPUT POWER DIAGRAMS**

**SHAFT END**

See **DT6E** Single Pumps for flow and input power diagrams (page 46)

**COVER END**

See **DT6D** Single Pumps for flow and input power diagrams (page 44)

**DOUBLE PUMPS DT6ED - DIMENSIONS**

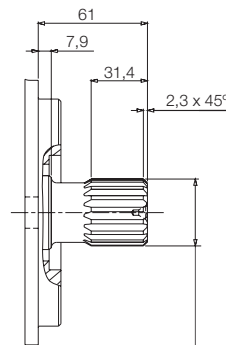
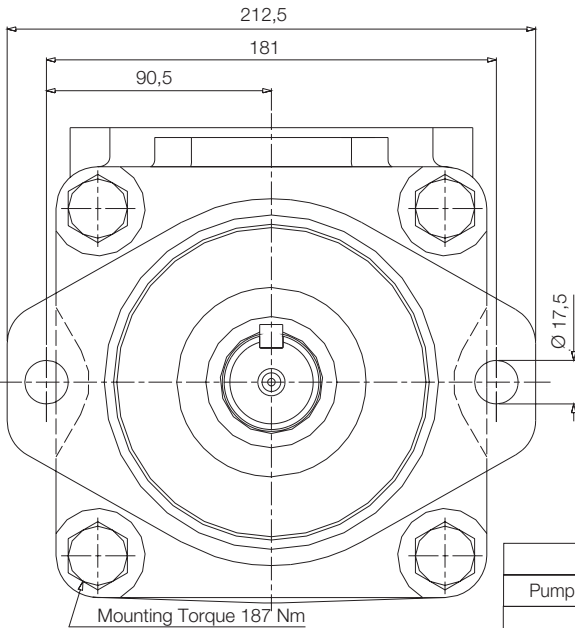

**Shaft Code 4**

SAE CC Splined shaft  
1-J498b 12/24 d.p. -  
17 Teeth  
30° Pressure angle

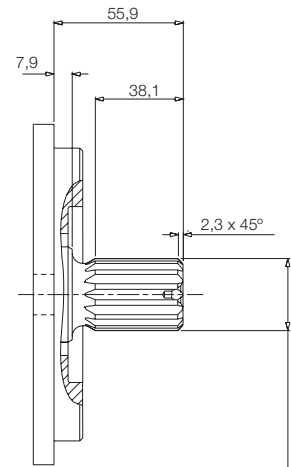

**Shaft Code 3**

SAE C Splined shaft  
1-J498b 12/24 d.p. -  
14 Teeth  
30° Pressure angle

Shaft Torque Limits (cc/rev x bar)		
Pump	Shaft Code	V x P max (P1+P2)
<b>DT6ED</b>	1	72306
	2	34590
	3	61200

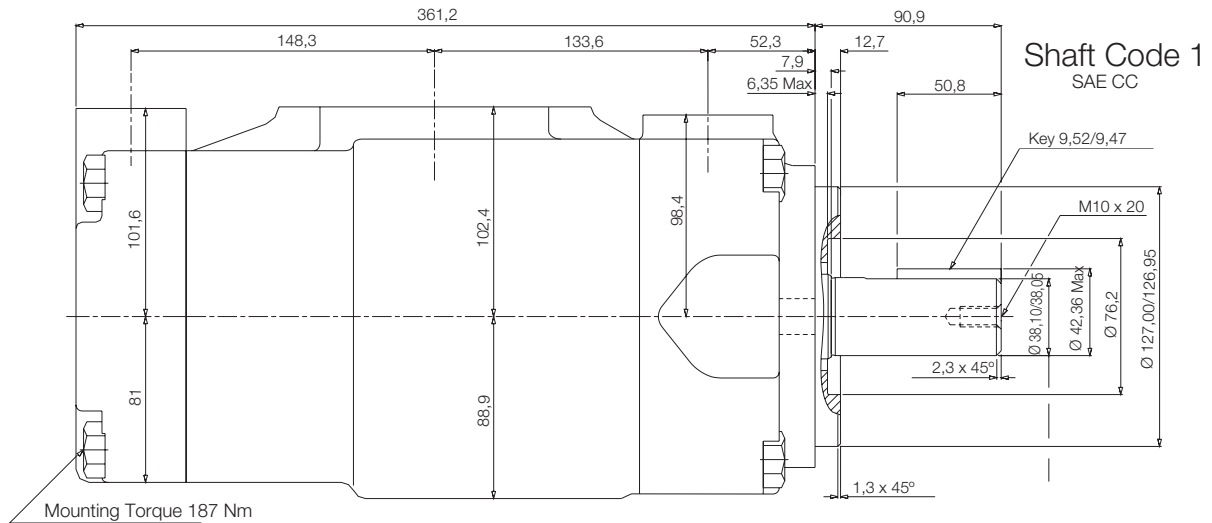

**Shaft Code 1**  
SAE CC

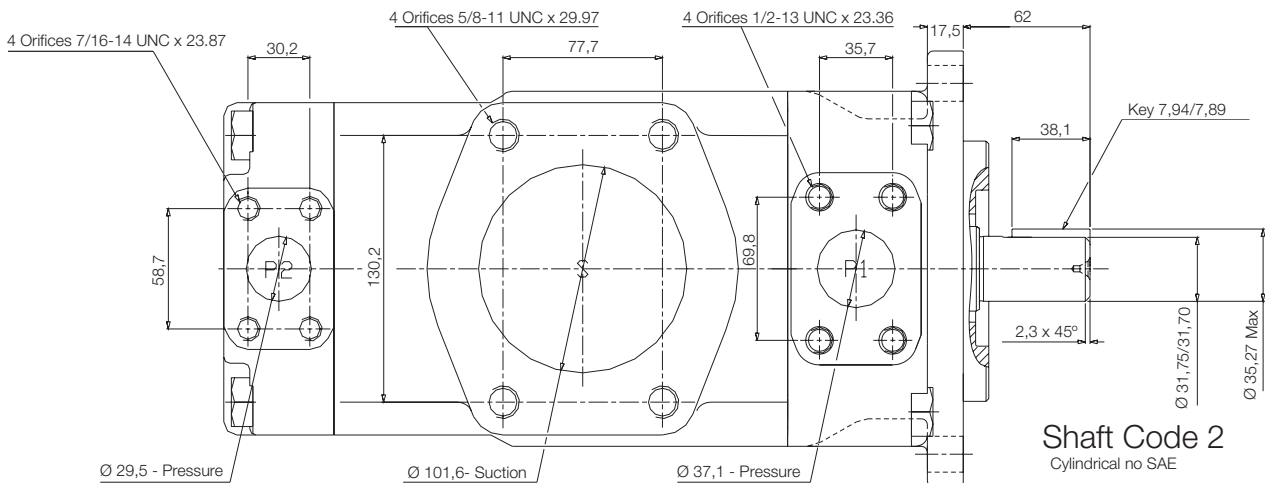

**Shaft Code 2**  
Cylindrical no SAE

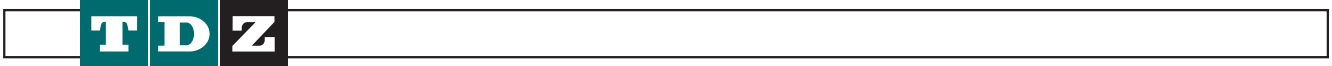

hydraulics

# **TRIPLE VANE PUMPS**

DT6 Triple vane pumps

## DT6 TRIPLE VANE PUMPS ORDERING CODE

**DT6 - DCC - B - 62/38/70 - 1 - R - 00 - B - 1 - M - 00**

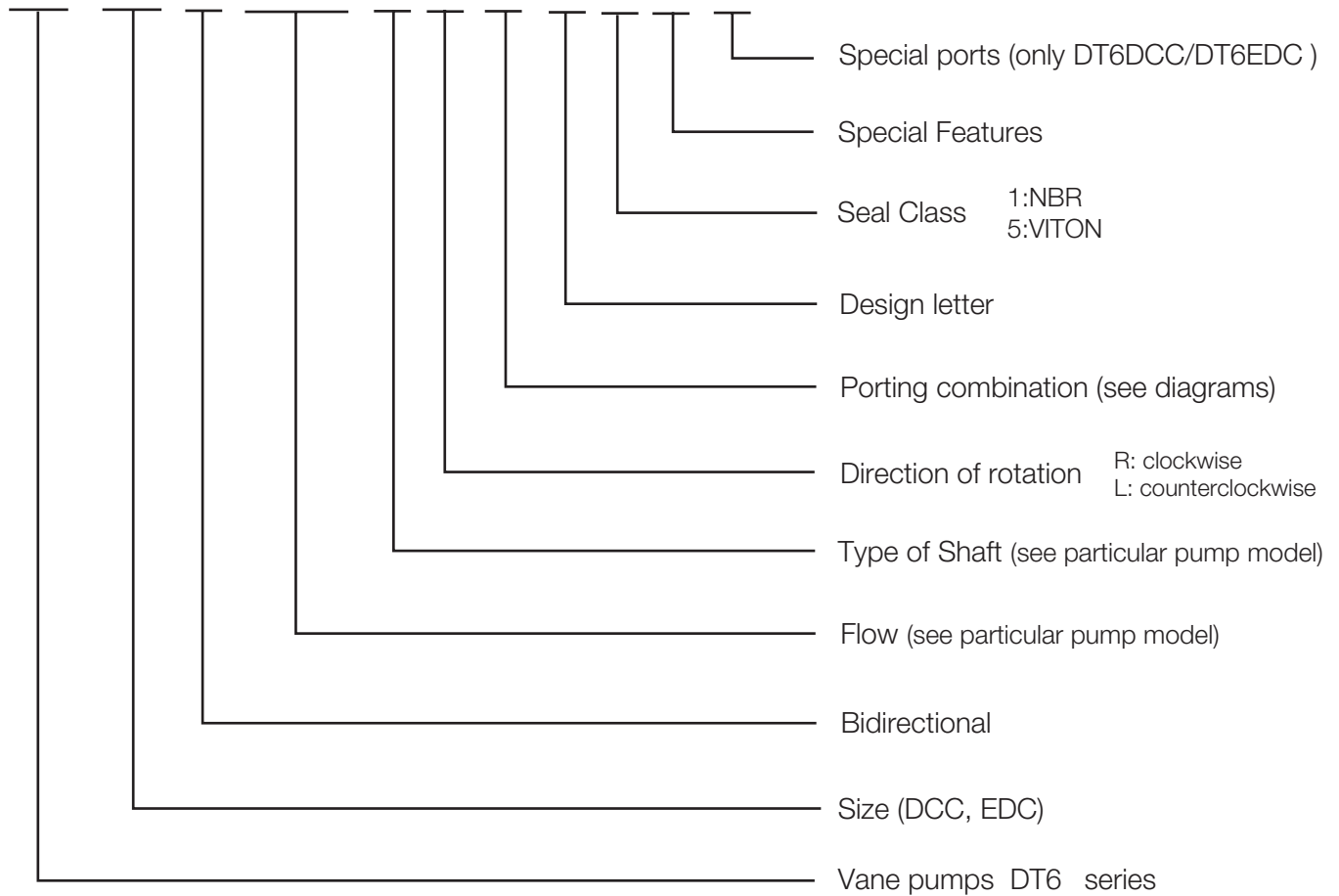

# DT6 TRIPLE VANE PUMPS - GENERAL CHARACTERISTICS



hydraulics

## TRIPLE VANE PUMPS

Series	P1			P2			P3			Maximum speed	Front Flange Standard SAE j744c ISO 3019-1	Weight Kgs	SAE 4 holes flange			
	Cartridge model	Theoretical displacem. Cm <sup>3</sup> /rev	Maximum Pressure	Cartridge model	Theoretical displacem. Cm <sup>3</sup> /rev	Maximum Pressure	Cartridge model	Theoretical displacem. Cm <sup>3</sup> /rev	Maximum Pressure				Suction S	Pressure		
														P1	P2	P3
DT6DCC	014 a 061	47.6 a 190.5	240	003 a 031	10.8 a 100	275	003 a 031	10.8 a 100	275	2500	SAE C	61	4"	1 1/4"	1"	1" 6/34"
DT6EDC	042 a 085	132.3 a 269.8	240	014 a 061	47.6 a 190.5	240	003 a 031	10.8 a 100	275	2200	ISO 3019-2	100	4"	1 1/2"	1 1/4"	1" 6/34"

C - 025,028,031 - 2500 rpm maximum, 028,031 - 210 bar maximum intermitent  
 D - 042,045,050 - 2200 rpm maximum, 050 - 210 bar maximum intermitent - 061 - 120 bar max intermitente  
 E - 085 - 2000 rpm max - 90 bar maximum intermitent

## TRIPLE VANE PUMPS - PORTING COMBINATION

## DT6DCC-DT6EDC

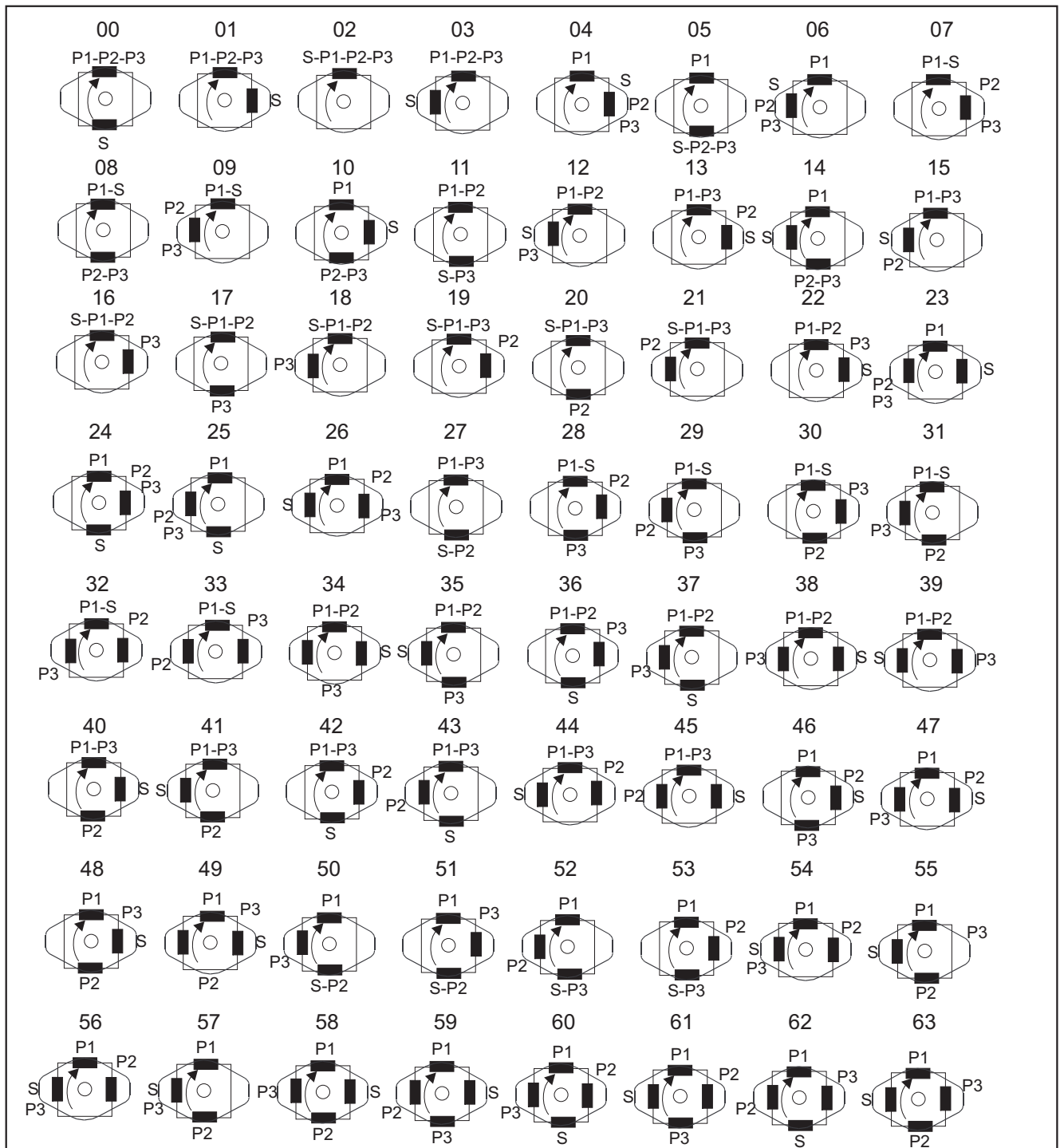

S= Suction port | P1= Shaft end pressure port | P2= Middle pressure port | P3= Cover end pressure port

## DT6DCC - OPERATING CHARACTERISTICS

### SHAFT END SECTION

	FLOW										SPEED (rpm)		PRESSURE (bar)		WEIGHT (Kgs.)	
											Mín.	Máx.	Intermit.	Contin.		
<b>Lts/min.at 1000 rpm</b>	48	66	80	90	98	111	120	136	146	158	191	Mín.	Máx.	Intermit.	Contin.	24
<b>Gal/min.at 1200 rpm</b>	14	20	24	28	31	35	38	42	45	50	61	400	2500*	240	210	

\* See page 41 for further information about speed & pressure.

### MIDDLE SECTION

	FLOW										SPEED (rpm)		PRESSURE (bar)		WEIGHT (Kgs.)			
											Mín.	Máx.	Intermit.	Contin.				
<b>Lts/min.at 1000 rpm</b>	11	17	21	26	34	37	46	58	64	70	79	89	100	Mín.	Máx.	Intermit.	Contin.	15
<b>Gal/min.at 1200 rpm</b>	3	5	6	8	10	12	14	17	20	22	25	28	31	400	2800*	275	240*	

\* See page 41 for further information about speed & pressure.

### COVER END SECTION

	FLOW										SPEED (rpm)		PRESSURE (bar)		WEIGHT (Kgs.)			
											Mín.	Máx.	Intermit.	Contin.				
<b>Lts/min.at 1000 rpm</b>	11	17	21	26	34	37	46	58	64	70	79	89	100	Mín.	Máx.	Intermit.	Contin.	15
<b>Gal/min.at 1200 rpm</b>	3	5	6	8	10	12	14	17	20	22	25	28	31	400	2800*	275	240*	

\* See page 41 for further information about speed & pressure.

## DT6DCC - FLOW & INPUT POWER DIAGRAMS

### SHAFT END

See **DT6D** Single Pumps for flow and input power diagrams (page 44)

### MIDDLE BODY

See **DT6C** Single Pumps for flow and input power diagrams (page 42)

### COVER END

See **DT6C** Single Pumps for flow and input power diagrams (page 42)





**DT6EDC - OPERATING CHARACTERISTICS**

**SHAFT END SECTION**

	FLOW								SPEED (rpm)		PRESSURE (bar)		WEIGHT (Kgs.)
	Lts/min.at 1000 rpm	132	142	156	165	197	213	227	270	Mín.	Máx.	Intermit.	
Gal/min.at 1200 rpm	42	45	50	52	62	66	72	85	400	2200*	240	210	44

\* See page 41 for further information about speed & pressure.

**MIDDLE SECTION**

	FLOW										SPEED (rpm)		PRESSURE (bar)		WEIGHT (Kgs.)	
	Lts/min.at 1000 rpm	48	66	80	90	98	111	120	136	146	158	191	Mín.	Máx.		Intermit.
Gal/min.at 1200 rpm	14	20	24	28	31	35	38	42	45	50	61	400	2500*	240	210	24

\* See page 41 for further information about speed & pressure.

**COVER END SECTION**

	FLOW												SPEED (rpm)		PRESSURE (bar)		WEIGHT (Kgs.)	
	Lts/min.at 1000 rpm	11	17	21	26	34	37	46	58	64	70	79	89	100	Mín.	Máx.		Intermit.
Gal/min.at 1200 rpm	3	5	6	8	10	12	14	17	20	22	25	28	31	400	2800*	275	240*	15

\* See page 41 for further information about speed & pressure.

**DT6EDC - FLOW & INPUT POWER DIAGRAMS**

**SHAFT END**

See **DT6E** Single Pumps for flow and input power diagrams (page 46)

**MIDDLE BODY**

See **DT6D** Single Pumps for flow and input power diagrams (page 44)

**COVER END**

See **DT6C** Single Pumps for flow and input power diagrams (page 42)

**TRIPLE PUMPS DT6EDC/DT6EDCM - DIMENSIONS**

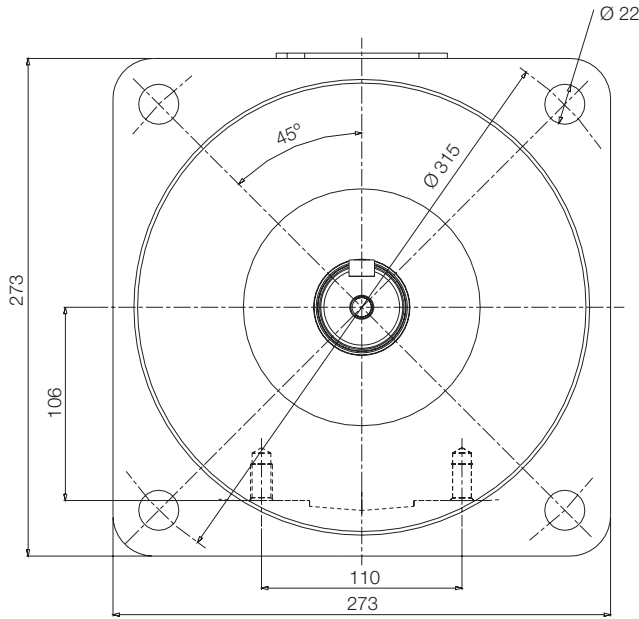

Alternative ports				
Orifice	Code	A	B	C
P3	<b>00*</b>	52,4	26,2	25,4
P3	<b>01*</b>	47,6	22,1	19,0

\*Add the following numbers at the end of the **T6EDC** reference depending your option.

Please, contact **TDZ** for special shaft codes not included in this catalogue.

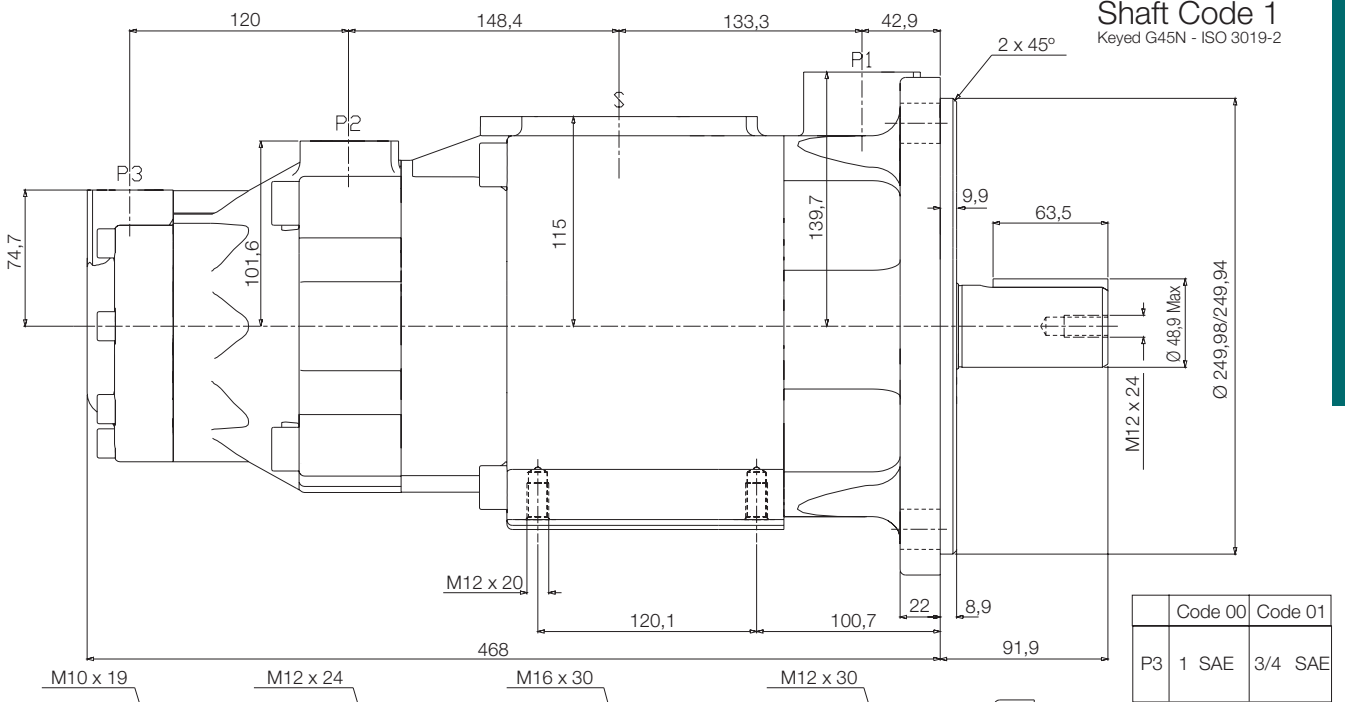

Shaft Code 1  
Keyed G45N - ISO 3019-2

